

**Air Preparation Products  
Prep-Air® II Products**

**Particulate Filters**

- [05F Economy](#)
- [06F Compact](#)
- [07F Standard](#)

**Coalescing Filters**

- [15F Economy](#)
- [11F Compact](#)
- [12F Standard](#)

**Regulators**

- [05R Economy](#)
- [06R Compact](#)
- [07R Standard](#)

**Pilot Controlled Regulators**

- [11R Economy](#)
- [12R Standard](#)

**Filter / Regulators**

- [05E Economy](#)
- [06E Compact](#)
- [07E Standard](#)
- [12E Coalescing](#)

**Lubricators**

- [15L Economy, Micro-Mist](#)
- [16L Compact, Micro-Mist](#)
- [17L Standard, Micro-Mist](#)
- [06L Compact, Mist](#)
- [07L Standard, Mist](#)

**Combinations**

- [06 Compact & 07 Standard, Close Nipped](#)
- [06 Compact & 07 Standard, Modular](#)
- [Accessories](#)

**Accessories**

- [06S & 07S Soft Start / Quick Dump Valves](#)
- [06T & 07T Solenoid Quick Dump Valves](#)
- [06P & 07P Auto Pilot Soft Start Valve](#)
- [Mounting Bracket Kits](#)
- [Remote Auto-Fill Device](#)

Prep-Air® II  
Products



**05F Particulate Filters – Economy**

- Excellent water removal efficiency
- Unique deflector plate and shroud creates a swirling of the air stream ensuring maximum water and dirt separation
- Large filter element surface guarantees low pressure drop and increased element life
- 40 micron filter element standard
- Shown with recommended metal bowl guard
- 1/4" & 3/8" ports (NPT)

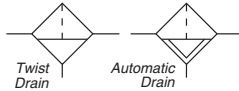

Port size	Description ‡	Part number
1/4"	Poly bowl, metal guard, twist drain	<b>05F12AA</b>
1/4"	Poly bowl, metal guard, auto pulse drain	<b>05F1PAA</b>
3/8"	Poly bowl, metal guard, twist drain	<b>05F22AA</b>
3/8"	Poly bowl, metal guard, auto pulse drain	<b>05F2PAA</b>

‡ For polycarbonate bowl and sight dome, see caution in Engineering Section A.

**Operating information**

Supply pressure (max):	
Plastic bowl	
Without DPI	0 to 150 psig (0 to 10.3 bar)
With DPI	0 to 150 psig (0 to 10.3 bar)
Auto pulse drain	10 to 150 psig (0.7 to 10.3 bar)
Operating temperature:	
Plastic bowl	32°F to 125°F (0°C to 52°C)
With DPI	32°F to 125°F (0°C to 52°C)
Flow capacity†:	
High flow	
1/4"	54 scfm (25.5 dm³/s, ANR)
3/8"	70 scfm (33 dm³/s, ANR)
Bowl capacity:	2.0 oz.
Sump capacity:	0.9 oz.
Weight:	1.2 lb (0.54 kg)
† scfm = Standard cubic feet per minute at 90 psig inlet and 5 psig pressure drop.	
DPI = Differential pressure indicator	

**Ordering information:**

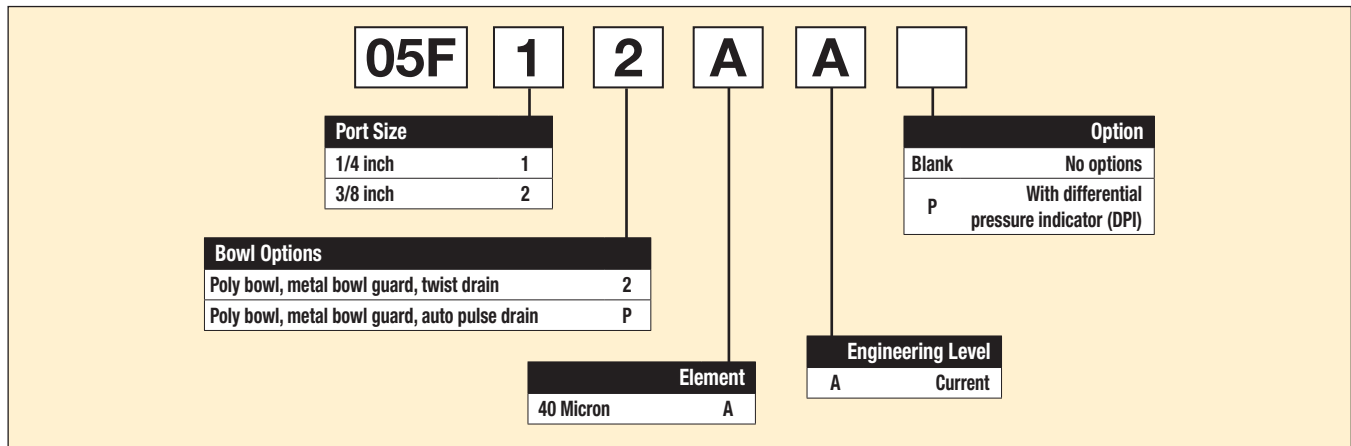

Most popular.



## Economy Particulate Filters

### Material Specifications

Body	Zinc
Transparent bowl	Polycarbonate
Bowl guards	Steel
Collar	Plastic
Deflector, shroud & baffle	Plastic
Drain	Plastic
Element	Plastic
Adsorber (optional)	Activated charcoal
Seals	Nitrile
Sight gauge, DPI	Polyamide (nylon)

### Repair and Service Kits

Bowl guard kit	<b>PS905P</b>
Poly bowl / auto pulse drain	<b>PS995P</b>
Poly bowl / twist drain	<b>PS932P</b>
Auto pulse drain	<b>PS998P</b>
Twist drain	<b>PS512P</b>
40 micron element	<b>PS901P</b>
Adsorber	<b>PS931P</b>
Mounting bracket kit	<b>PS943P</b>
Sight gauge kit	<b>PS914P</b>

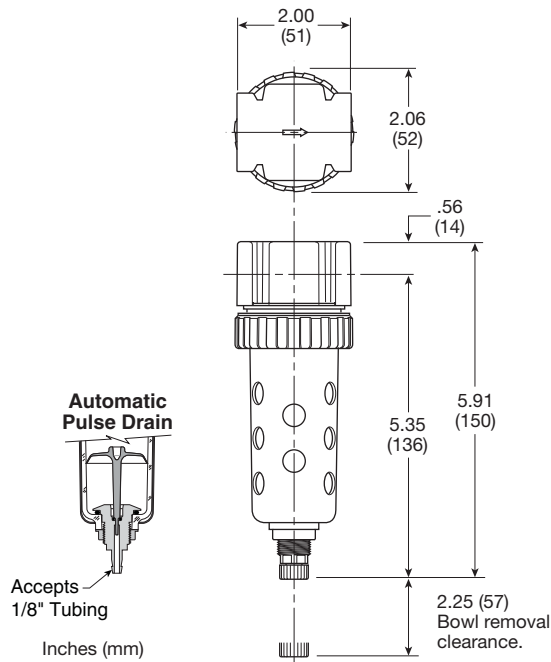

## Air Preparation Products Prep-Air® II Series

### Flow Charts

#### 05F 1/4" Particulate Filter

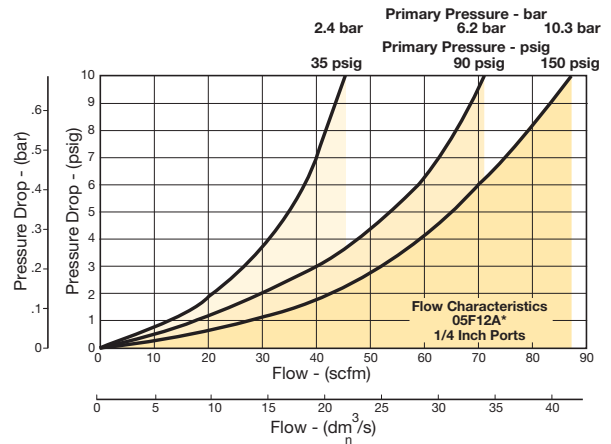

#### 05F 3/8" Particulate Filter

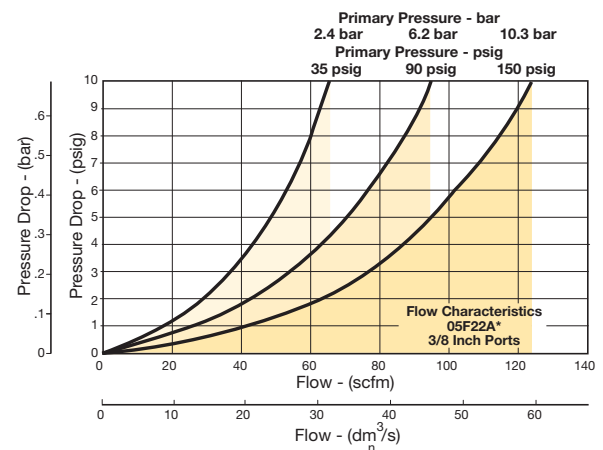

Prep-Air® II  
Products



Filters

Coalescers

Regulators

Filter/  
Regulators

Lubricators

Combinations

Accessories

**06F Particulate Filters – Compact**

- Excellent water removal efficiency
- Unique deflector plate and shroud creates a swirling of the air stream ensuring maximum water and dirt separation
- Large filter element surface guarantees low pressure drop and increased element life
- Optional automatic float drain available
- Shown with recommended metal bowl guard
- 1/4", 3/8", 1/2" ports – NPT, BSPP

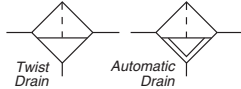

Port size	Description †	Part number
1/4"	Poly bowl, metal guard, twist drain	<b>06F12AC</b>
1/4"	Metal bowl, sight gauge, twist drain	<b>06F14AC</b>
1/4"	Poly bowl, metal guard, auto float drain	<b>06F16AC</b>
1/4"	Metal bowl, sight gauge, auto float drain	<b>06F18AC</b>
3/8"	Poly bowl, metal guard, twist drain	<b>06F22AC</b>
3/8"	Metal bowl, sight gauge, twist drain	<b>06F24AC</b>
3/8"	Poly bowl, metal guard, auto float drain	<b>06F26AC</b>
3/8"	Metal bowl, sight gauge, auto float drain	<b>06F28AC</b>
1/2"	Poly bowl, metal guard, twist drain	<b>06F32AC</b>
1/2"	Metal bowl, sight gauge, twist drain	<b>06F34AC</b>
1/2"	Poly bowl, metal guard, auto float drain	<b>06F36AC</b>
1/2"	Metal bowl, sight gauge, auto float drain	<b>06F38AC</b>

† For polycarbonate bowl and sight dome, see caution in Engineering Section A.

**Operating information**

Supply pressure (max):	
Without DPI	
Plastic bowl	0 to 150 psig (0 to 10.3 bar)
Metal bowl	0 to 250 psig (0 to 17.2 bar)
With DPI	
Auto float drain	0 to 150 psig (0 to 10.3 bar) 15 to 250 psig (1.0 to 17.2 bar)
Operating temperature:	
Plastic bowl	32°F to 125°F (0°C to 52°C)
Metal bowl	32°F to 175°F (0°C to 80°C)
With DPI	32°F to 125°F (0°C to 52°C)
Flow capacity†:	
High flow	1/4" 53 scfm (25 dm³/s, ANR) 3/8" 80 scfm (37.8 dm³/s, ANR) 1/2" 85 scfm (40.1 dm³/s, ANR)
Bowl capacity:	4.4 oz.
Sump capacity:	1.75 oz.
Weight:	1.4 lb (0.6 kg)

† scfm = Standard cubic feet per minute at 90 psig inlet and 5 psig pressure drop.

DPI = Differential pressure indicator

**Ordering information:**

<b>06F</b>	<b>1</b>	<b>2</b>	<b>A</b>	<b>C</b>	<b> </b>
	<b>Port Size</b>				<b>Port Type</b>
	1/4 inch	1			Blank
	3/8 inch	2			1*
	1/2 inch	3			BSPP
					* 1/4 & 3/8 inch meets ISO 1179-1 standard.
	<b>Bowl Options</b>			<b>Engineering Level</b>	
	Poly bowl, metal bowl guard, twist drain	2		C	Current
	Poly bowl, metal bowl guard, auto float drain	6			
	Metal bowl, twist drain	3			
	Metal bowl, sight gauge, twist drain	4			
	Metal bowl, auto float drain	7			
	Metal bowl, sight gauge, auto float drain	8			
			<b>Element</b>		
			A	40 Micron	
			B	5 Micron	

Most popular.





## Compact Particulate Filters

### Material Specifications

Body	Zinc
Transparent bowl	Polycarbonate
Metal bowl with or without sight gauge	Zinc
Bowl Guards	Steel
Collar	Plastic
Deflector, shroud & baffle	Plastic
Twist drain - body & nut	Plastic
Auto float drain - housing, float	Plastic
Auto float drain - seals	Nitrile
Auto float drain - springs, push rod	Stainless steel
Element	Plastic
Adsorber (optional)	Activated charcoal
Seals	Nitrile
Sight gauge	Polyamide

### Repair and Service Kits

Bowl guard kit	PS705P
Poly bowl / auto float drain kit	PS722P
Poly bowl / twist drain kit	PS732P
Metal bowl / auto float drain kit	PS726P
Metal bowl / twist drain kit	PS734P
Metal bowl / sight gauge / auto float drain kit	PS723P
Metal bowl / sight gauge / twist drain kit	PS735P
Auto float drain kit	PS506P
Twist drain kit	PS512P
40 micron element	PS701P
5 micron element	PS702P
Adsorber element	PS731P
Mounting bracket kit	PS743P
Sight gauge kit	PS914P

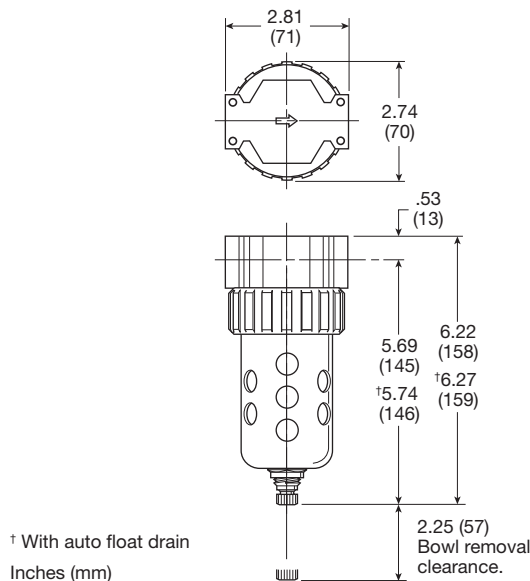

## Air Preparation Products Prep-Air® II Series

### Flow Charts

#### 06F 1/4" Particulate Filter

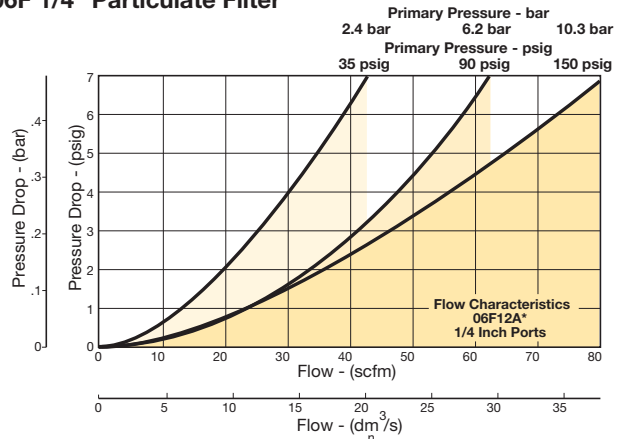

#### 06F 3/8" Particulate Filter

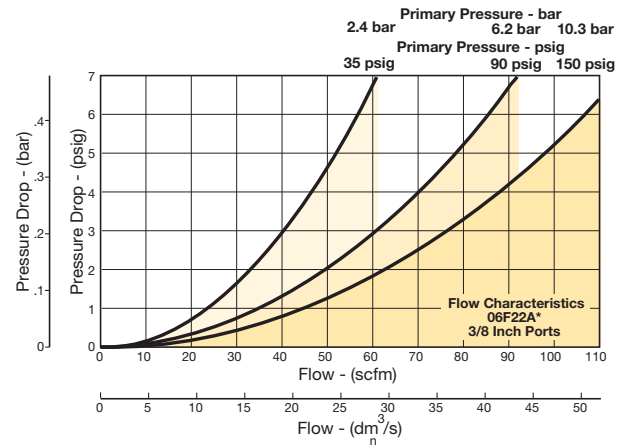

#### 06F 1/2" Particulate Filter

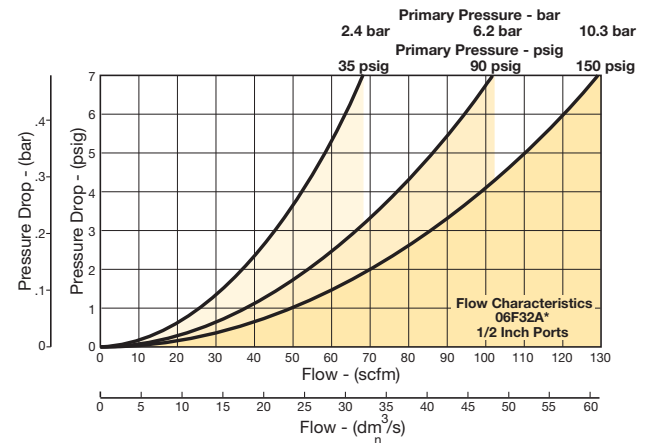

Prep-Air® II  
Products



Filters

Coalescers

Regulators

Filter /  
Regulators

Lubricators

Combinations

Accessories

**07F Particulate Filters – Standard**

- Excellent water removal efficiency.
- Unique deflector plate and shroud creates a swirling of the air stream ensuring maximum water and dirt separation.
- Large filter element surface guarantees low pressure drop and increased element life.
- Optional automatic float drain available.
- Shown with recommended metal bowl guard.
- 1/2", 3/4" ports – NPT, BSPP

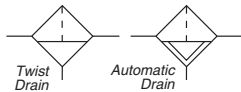

Port size	Description †	Part number
1/2"	Poly bowl, metal guard, twist drain	<b>07F32AC</b>
1/2"	Metal bowl, sight gauge, twist drain	<b>07F34AC</b>
1/2"	Poly bowl, metal guard, auto float drain	<b>07F36AC</b>
1/2"	Metal bowl, sight gauge, auto float drain	<b>07F38AC</b>
3/4"	Poly bowl, metal guard, twist drain	<b>07F42AC</b>
3/4"	Metal bowl, sight gauge, twist drain	<b>07F44AC</b>
3/4"	Poly bowl, metal guard, auto float drain	<b>07F46AC</b>
3/4"	Metal bowl, sight gauge, auto float drain	<b>07F48AC</b>

† For polycarbonate bowl and sight dome, see caution in Engineering Section A.

**Operating information**

Supply pressure (max):  
 Without DPI  
 Plastic bowl 0 to 150 psig (0 to 10.3 bar)  
 Metal bowl 0 to 250 psig (0 to 17.2 bar)  
 With DPI  
 Auto float drain 15 to 250 psig (1.0 to 17.2 bar)

Operating temperature:  
 Plastic bowl 32°F to 125°F (0°C to 52°C)  
 Metal bowl 32°F to 175°F (0°C to 80°C)  
 With DPI 32°F to 125°F (0°C to 52°C)

Flow capacity†:  
 High flow 1/2" 130 scfm (61.4 dm³/s, ANR)  
 3/4" 145 scfm (68.4 dm³/s, ANR)

Bowl capacity: 7.2 oz.  
 Sump capacity: 2.8 oz.  
 Weight: 2.2 lb (1.0 kg)

† scfm = Standard cubic feet per minute at 90 psig inlet and 5 psig pressure drop.  
 DPI = Differential pressure indicator

**Ordering information:**

<b>07F</b>	<b>3</b>	<b>2</b>	<b>A</b>	<b>C</b>	
<b>Port Size</b>					<b>Port Type</b>
1/2 inch	3				Blank NPT
3/4 inch	4				1* BSPP
					* 1/2 inch meets ISO 1179-1 standard.
<b>Bowl Options</b>				<b>Engineering Level</b>	
Poly bowl, metal bowl guard, twist drain	2			C	Current
Poly bowl, metal bowl guard, auto float drain	6				
Metal bowl, twist drain	3				
Metal bowl, sight gauge, twist drain	4				
Metal bowl, auto float drain	7				
Metal bowl, sight gauge, auto float drain	8				
			<b>Element</b>		
			A	40 Micron	
			B	5 Micron	

Most popular.



## Standard Particulate Filters

### Material Specifications

Body	Zinc
Transparent bowl	Polycarbonate
Metal bowl with or without sight gauge	Zinc
Bowl guards	Steel
Collar	Plastic or metal
Deflector, shroud & baffle	Plastic
Twist drain, body & nut	Plastic
Auto float drain – housing, float	Plastic
Auto float drain – seals	Nitrile
Auto float drain – springs, push rod	Stainless steel
Element	Plastic
Adsorber element (optional)	Activated charcoal
Seals	Nitrile
Sight gauge	Polyamide

### Repair and Service Kits

Bowl guard kit	<b>PS805P</b>
Poly bowl / auto float drain kit	<b>PS822P</b>
Poly bowl / twist drain kit	<b>PS832P</b>
Metal bowl / auto float drain kit	<b>PS826P</b>
Metal bowl / twist drain kit	<b>PS834P</b>
Metal bowl / sight gauge / auto drain kit	<b>PS823P</b>
Metal bowl / sight gauge / twist drain kit	<b>PS835P</b>
Auto float drain kit	<b>PS506P</b>
Twist drain kit	<b>PS512P</b>
40 micron element	<b>PS801P</b>
5 micron element	<b>PS802P</b>
Adsorber element	<b>PS831P</b>
Mounting bracket kit	<b>PS843P</b>
Sight gauge kit	<b>PS914P</b>

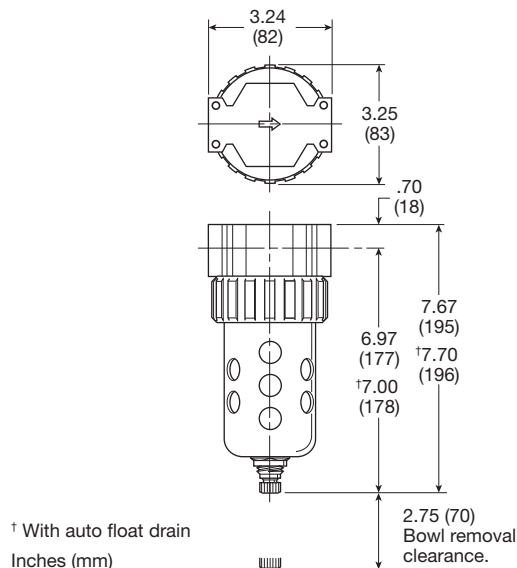

## Air Preparation Products Prep-Air® II Series

### Flow Charts

#### 07F 1/2" Particulate Filter

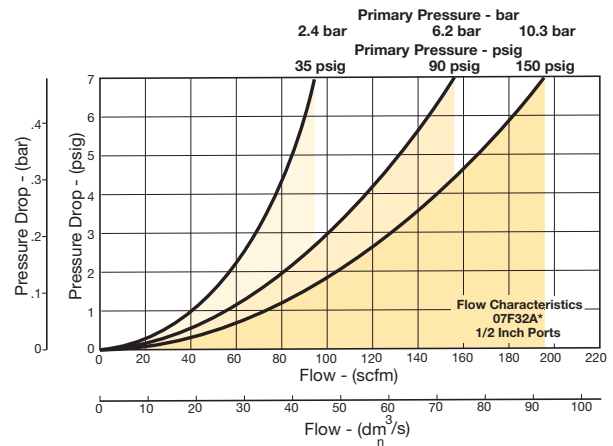

#### 07F 3/4" Particulate Filter

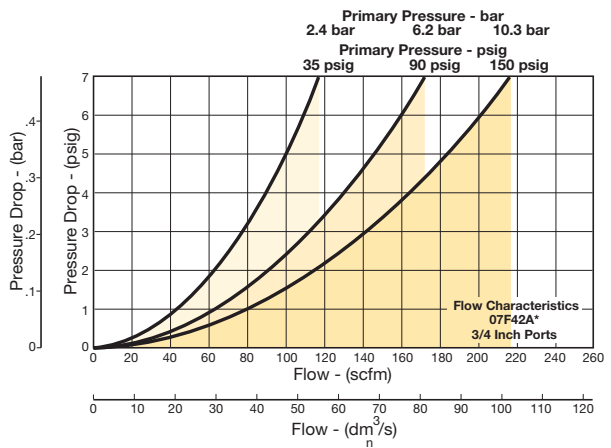

Prep-Air® II  
Products



Filters

Coalescers

Regulators

Filter/  
Regulators

Lubricators

Combinations

Accessories

**15F Coalescing Filters – Economy**

- Removes liquid aerosols and sub-micron particles.
- Liquids gravitate to the bottom of the element and will not re-enter the airstream.
- Oil free air for critical applications, such as air gauging and pneumatic instrumentation and controls.
- Interchangeable twist and automatic pulse drains.
- Differential pressure indicator standard.
- 1/4" & 3/8" ports – NPT

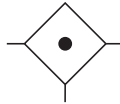

Port size	Description ‡	Part number
1/4"	Poly bowl, metal guard, twist drain	<b>15F12EA</b>
1/4"	Poly bowl, metal guard, auto pulse drain	<b>15F1PEA</b>
3/8"	Poly bowl, metal guard, twist drain	<b>15F22EA</b>
3/8"	Poly bowl, metal guard, auto pulse drain	<b>15F2PEA</b>

‡ For polycarbonate bowl, see caution in Engineering Section A.

**Operating information**

Supply pressure (max):	
Plastic bowl	
Without DPI	0 to 150 psig (0 to 10.3 bar)
With DPI	0 to 150 psig (0 to 10.3 bar)
Auto pulse drain	10 to 150 psig (0.7 to 10.3 bar)
Operating temperature:	
Plastic bowl	
With DPI	32°F to 125°F (0°C to 52°C)
Without DPI	32°F to 125°F (0°C to 52°C)
Flow capacity†:	Grade 6
	1/8" 30 scfm (14.2 dm <sup>3</sup> /s, ANR)
	1/4" 30 scfm (14.2 dm <sup>3</sup> /s, ANR)
Bowl capacity:	2.0 oz.
Sump capacity:	0.9 oz.
Weight:	1.2 lb (0.54 kg)

† scfm = Standard cubic feet per minute at 90 psig inlet and 5 psig pressure drop.  
DPI = Differential pressure indicator

**Ordering information:**

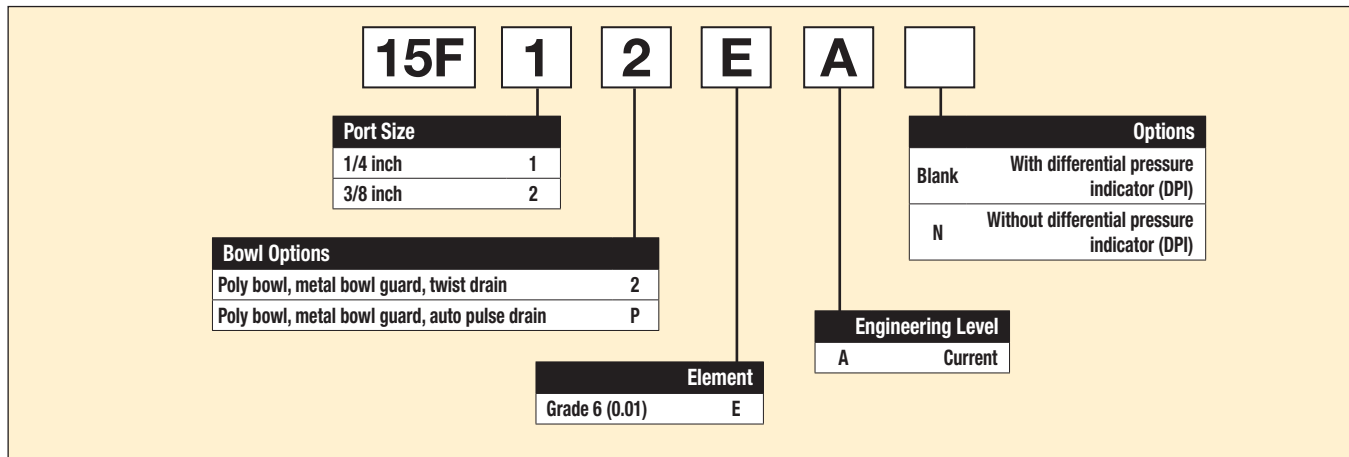

Most popular.



## Economy Coalescing Filters

### Material Specifications

Body	Zinc
Transparent bowl	Polycarbonate
Bowl guards	Steel
Collar	Plastic
Drain	Plastic
Element	Borosilicate & felt glass fibers
Seals	Nitrile
Sight gauge, DPI	Polyamide (nylon)

### Repair and Service Kits

Bowl Guard Kit	<b>PS905P</b>
Poly bowl / automatic pulse drain kit	<b>PS995P</b>
Poly bowl / twist drain kit	<b>PS932P</b>
DPI replacement kit	<b>PS781P</b>
Electronic DPI replacement kit	<b>PS764</b>
Automatic pulse drain kit	<b>PS998P</b>
Twist drain kit	<b>PS512P</b>
Electrical connector: 15mm, 3-pin DIN, 6 ft. cord	<b>PS2932JBP</b>
Filter element kits – Grade 6 (standard)	<b>PS924P</b>
Mounting bracket kit	<b>PS943P</b>
Sight gauge kit	<b>PS914P</b>

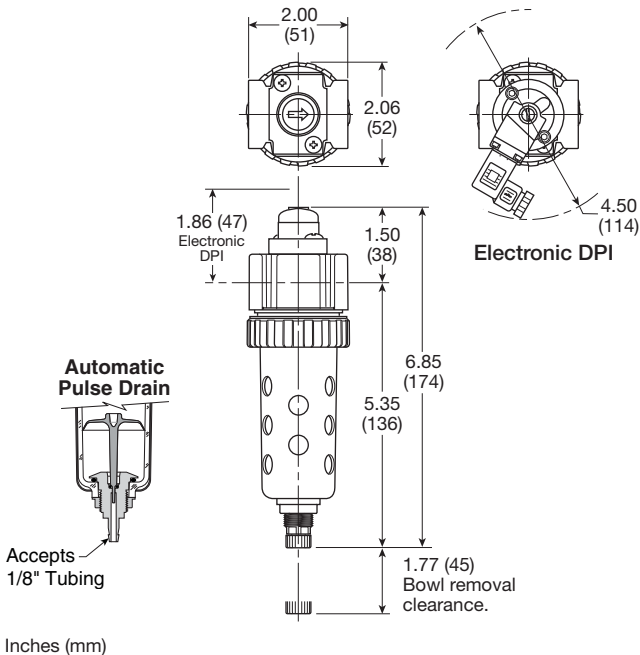

## Air Preparation Products Prep-Air® II Series

### Flow Charts

#### Grade 6 Element

##### 15F 1/4" Coalescing Filter

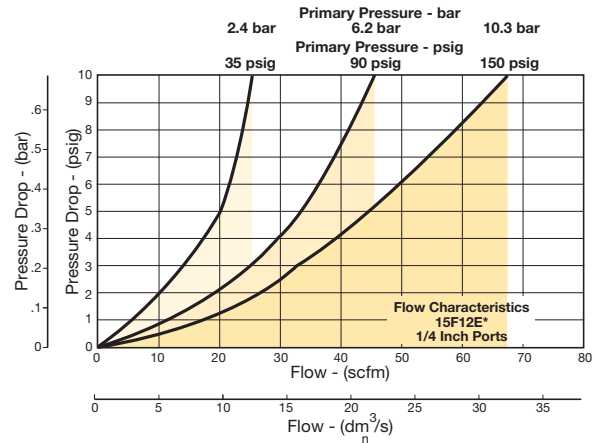

##### 15F 3/8" Coalescing Filter

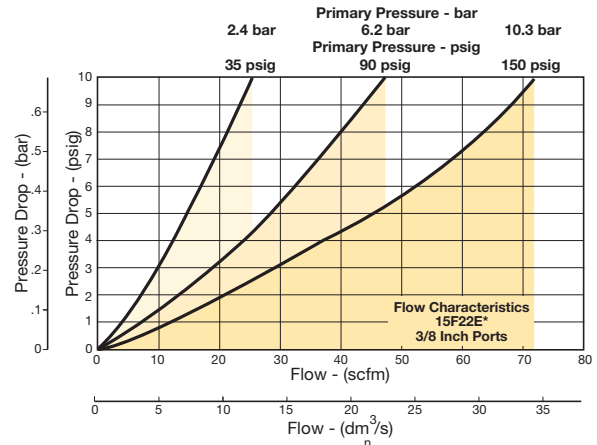

Prep-Air® II  
Products



Filters

Coalescers

Regulators

Filter /  
Regulators

Lubricators

Combinations

Accessories



**11F Coalescing Filters – Compact**

- Removes liquid aerosols and sub-micron particles.
- Liquids gravitate to the bottom of the element and will not re-enter the airstream
- Oil free air for critical applications, such as air gauging and pneumatic instrumentation and controls.
- Interchangeable twist and automatic float drains.
- Differential pressure indicator standard.
- Shown with recommended metal bowl guard.
- 1/4", 3/8", 1/2" ports (NPT, BSPP)

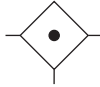

Port size	Description †	Part number
1/4"	Poly bowl, metal guard, twist drain	<b>11F12EC</b>
1/4"	Metal bowl, sight gauge, twist drain	<b>11F14EC</b>
1/4"	Poly bowl, metal guard, auto float drain	<b>11F16EC</b>
1/4"	Metal bowl, sight gauge, auto float drain	<b>11F18EC</b>
3/8"	Poly bowl, metal guard, twist drain	<b>11F22EC</b>
3/8"	Metal bowl, sight gauge, twist drain	<b>11F24EC</b>
3/8"	Poly bowl, metal guard, auto float drain	<b>11F26EC</b>
3/8"	Metal bowl, sight gauge, auto float drain	<b>11F28EC</b>
1/2"	Poly bowl, metal guard, twist drain	<b>11F32EC</b>
1/2"	Metal bowl, sight gauge, twist drain	<b>11F34EC</b>
1/2"	Poly bowl, metal guard, auto float drain	<b>11F36EC</b>
1/2"	Metal bowl, sight gauge, auto float drain	<b>11F38EC</b>

Standard part numbers shown bold, with Grade 6 Elements (for Grade 10 Elements, replace "E" with "H" in the 6th position). For other models refer to ordering information below.

† For polycarbonate bowl, see caution in Engineering Section A.

**Operating information**

Supply pressure (max):	
Without DPI	
Plastic bowl	0 to 150 psig (0 to 10.3 bar)
Metal bowl	0 to 250 psig (0 to 17.2 bar)
With DPI	
Auto float drain	0 to 150 psig (0 to 10.3 bar)
Differential pressure indicator	15 to 250 psig (1.0 to 17.2 bar)
Operating pressure drop:	
Normal	2 psig (0.14 bar)
Max recommended	10 psig (0.7 bar)
(Element should be replaced)	
Minimum recommended flow:	20% nominal rating of element
Operating temperature:	
Plastic bowl	32°F to 125°F (0°C to 52°C)
Metal bowl	32°F to 175°F (0°C to 80°C)
With DPI	32°F to 125°F (0°C to 52°C)
Flow capacity†:	
Grade 6 (0.01 micron)	1/4" 45 scfm (21 dm <sup>3</sup> /s, ANR)
	3/8" 48 scfm (23 dm <sup>3</sup> /s, ANR)
	1/2" 65 scfm (31 dm <sup>3</sup> /s, ANR)
Grade 10 (1.0 micron)	1/4" 60 scfm (28.3 dm <sup>3</sup> /s, ANR)
	3/8" 72 scfm (34 dm <sup>3</sup> /s, ANR)
	1/2" 95 scfm (45 dm <sup>3</sup> /s, ANR)
Bowl capacity:	
	4.4 oz.
Sump capacity:	
	1.75 oz.
Weight:	
	1.5 lb (0.7 kg)
† scfm = Standard cubic feet per minute at 90 psig inlet and 5 psig pressure drop.	
DPI = Differential pressure indicator	

**Ordering information:**

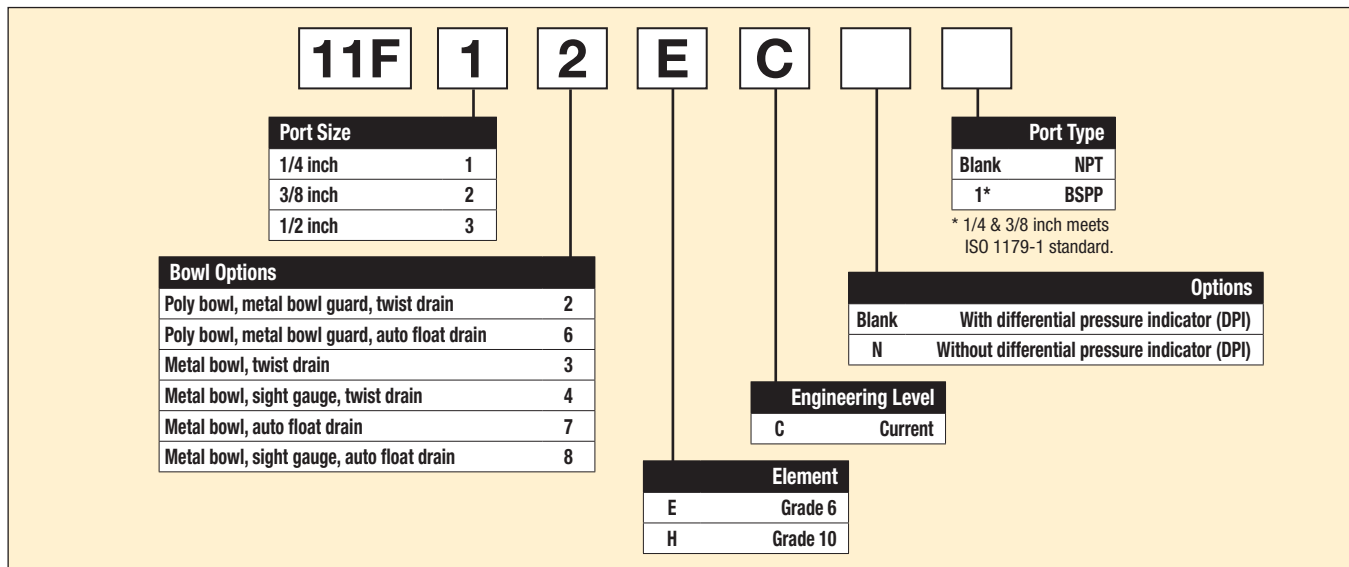

Most popular.

Prep-Air® II Products  
 Filters  
 Coalescers  
 Regulators  
 Filter / Regulators  
 Lubricators  
 Combinations  
 Accessories



**Material Specifications**

Body	Zinc
Transparent bowl	Polycarbonate
Metal bowl	Zinc
Bowl guard	Steel
Collar	Plastic
Twist drain, body & nut	Plastic
Push 'N' drain, body	Nitrile
Push 'N' drain, stem	Brass
Automatic float drain, housing, float	Plastic
Automatic float drain, seals	Nitrile
Automatic float drain, springs, push rod	Stainless steel
Element	Borosilicate & felt glass fibers
Seals	Nitrile
Sight gauge	Polyamide

**Repair and Service Kits**

Bowl guard kit	<b>PS705P</b>
Poly bowl / automatic float drain kit	<b>PS722P</b>
Poly bowl / twist drain kit	<b>PS732P</b>
Metal bowl / automatic float drain kit	<b>PS726P</b>
Metal bowl / twist drain kit	<b>PS734P</b>
Metal bowl / sight gauge / automatic float drain kit	<b>PS723P</b>
Metal bowl / sight gauge / twist drain kit	<b>PS735P</b>
DPI replacement kit	<b>PS781P</b>
Electronic DPI replacement kit	<b>PS764</b>
Automatic float drain kit	<b>PS506P</b>
Semi-auto drain kit	<b>PS511P</b>
Twist drain kit	<b>PS512P</b>
Push 'N' drain kit	<b>PS513P</b>
Electrical connector: 15mm, 3-pin DIN, 6 ft. cord	<b>PS2932JBP</b>
Grade 6 element (standard)	<b>PS724P</b>
Grade 10 element (optional)	<b>PS730P</b>
Mounting bracket kit	<b>PS743P</b>
Sight gauge kit	<b>PS914P</b>

**Flow Charts**

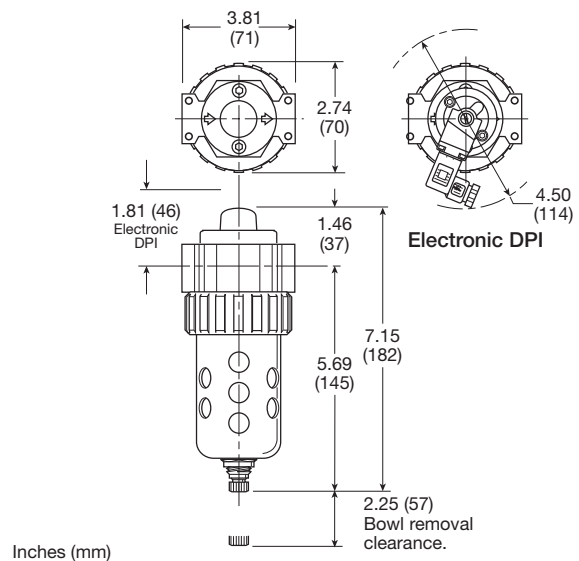
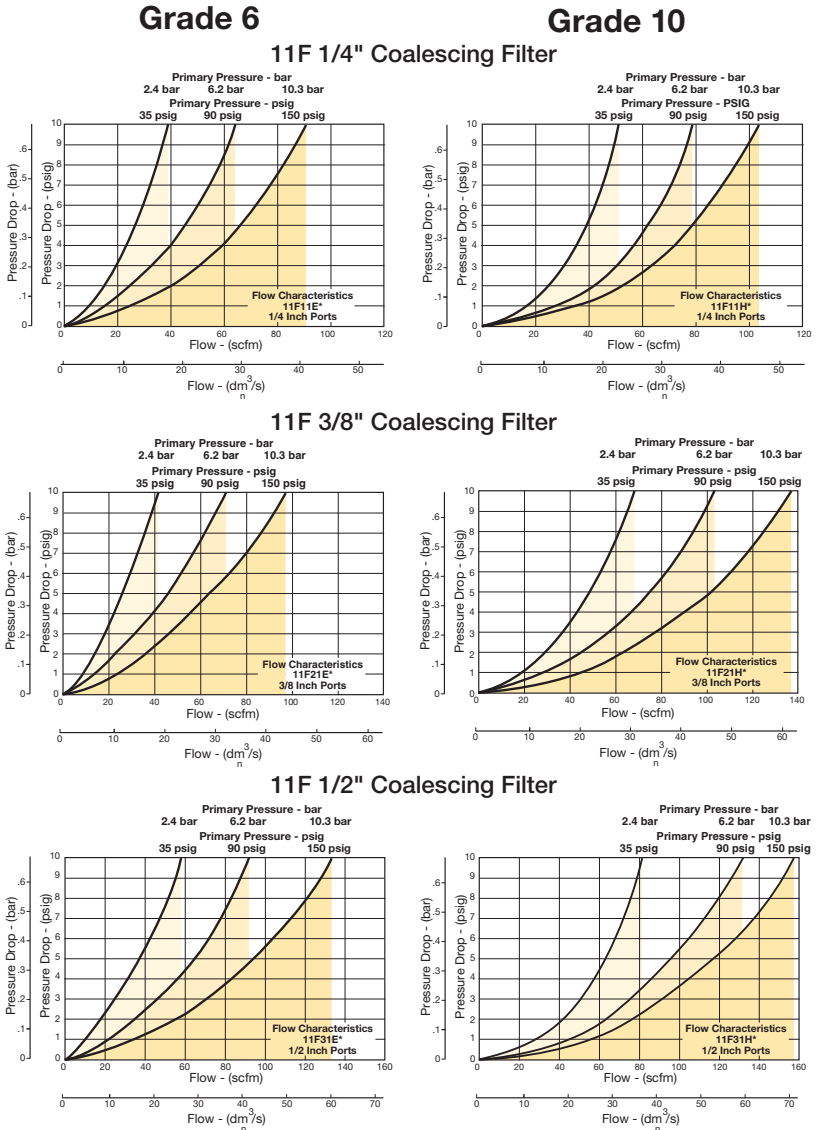

**Prep-Air® II Products**  
**Filters**  
**Coalescers**  
**Regulators**  
**Filter / Regulators**  
**Lubricators**  
**Combinations**  
**Accessories**





**12F Coalescing Filters – Standard**

- Removes liquid aerosols and sub-micron particles.
- Liquids gravitate to the bottom of the element and will not re-enter the airstream.
- Oil free air for critical applications, such as air gauging and pneumatic instrumentation and controls.
- Interchangeable twist and automatic float drains.
- Differential pressure indicator standard.
- Shown with recommended metal bowl guard.
- 1/2", 3/4" ports (NPT, BSPP)

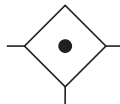

Port size	Description †	Part number
1/2"	Poly bowl, metal guard, twist drain	<b>12F32EC</b>
1/2"	Metal bowl, sight gauge, twist drain	<b>12F34EC</b>
1/2"	Poly bowl, metal guard, auto float drain	<b>12F36EC</b>
1/2"	Metal bowl, sight gauge, auto float drain	<b>12F38EC</b>
3/4"	Poly bowl, metal guard, twist drain	<b>12F42EC</b>
3/4"	Metal bowl, sight gauge, twist drain	<b>12F44EC</b>
3/4"	Poly bowl, metal guard, auto float drain	<b>12F46EC</b>
3/4"	Metal bowl, sight gauge, auto float drain	<b>12F48EC</b>

Standard part numbers shown bold, with Grade 6 Elements (for Grade 10 Elements, replace "E" with "H" in the 6th position). For other models refer to ordering information below.

† For polycarbonate bowl, see caution in Engineering Section A.

**Operating information**

Supply pressure (max):	
Without DPI	Plastic bowl 0 to 150 psig (0 to 10.3 bar) Metal bowl 0 to 250 psig (0 to 17.2 bar)
With DPI	0 to 150 psig (0 to 10.3 bar)
Auto float drain	15 to 250 psig (1.0 to 17.2 bar)
Operating pressure drop:	
Normal	2 psig (0.14 bar)
Max recommended (Element should be replaced)	10 psig (0.7 bar)
Minimum recommended flow:	20% nominal rating of element
Operating temperature:	
Plastic bowl	32°F to 125°F (0°C to 52°C)
Metal bowl	32°F to 175°F (0°C to 80°C)
With DPI	32°F to 125°F (0°C to 52°C)
Flow capacity†:	Grade 6 1/2" 75 scfm (35.4 dm <sup>3</sup> /s, ANR) 3/4" 80 scfm (37.7 dm <sup>3</sup> /s, ANR) Grade 10 1/2" 125 scfm (59 dm <sup>3</sup> /s, ANR) 3/4" 160 scfm (75.5 dm <sup>3</sup> /s, ANR)
Bowl capacity:	7.2 oz.
Sump capacity:	2.8 oz.
Weight:	2.4 lb (1.1 kg)
† scfm = Standard cubic feet per minute at 90 psig inlet and 5 psig pressure drop. DPI = Differential pressure indicator	

**Ordering information:**

<b>12F</b>	<b>3</b>	<b>2</b>	<b>E</b>	<b>C</b>		
<b>Port Size</b>					<b>Port Type</b>	
1/2 inch	3				Blank	NPT
3/4 inch	4				1*	BSPP
					* 1/2 inch meets ISO 1179-1 standard.	
<b>Bowl Options</b>					<b>Options</b>	
Poly bowl, metal bowl guard, twist drain		2			Blank	With differential pressure indicator (DPI)
Poly bowl, metal bowl guard, auto float drain		6			N	Without differential pressure indicator (DPI)
Metal bowl, twist drain		3				
Metal bowl, sight gauge, twist drain		4				
Metal bowl, auto float drain		7				
Metal bowl, sight gauge, auto float drain		8				
			<b>Engineering Level</b>			
			C	Current		
			<b>Element</b>			
			E	Grade 6		
			H	Grade 10		

Most popular.

Prep-Air® II Products  
 Filters  
 Coalescers  
 Regulators  
 Filter / Regulators  
 Lubricators  
 Combinations  
 Accessories





**Material Specifications**

Body	Zinc
Transparent bowl	Polycarbonate
Metal bowl with or without sight gauge	Zinc
Bowl guard	Steel
Collar	Plastic or metal
Twist drain, body & nut	Plastic
Push 'N' drain, body	Nitrile
Push 'N' drain, stem	Brass
Automatic float drain, housing, float	Plastic
Automatic float drain, seals	Nitrile
Automatic float drain, springs, push rod	Stainless steel
Element	Borosilicate & felt glass fibers
Seals	Nitrile
Sight gauge	Polyamide

**Repair and Service Kits**

Bowl guard kit	<b>PS805P</b>
Poly bowl / automatic float drain kit	<b>PS822P</b>
Poly bowl / twist drain kit	<b>PS832P</b>
Metal bowl / automatic float drain kit	<b>PS826P</b>
Metal bowl / twist drain kit	<b>PS834P</b>
Metal bowl / sight gauge / automatic float drain kit	<b>PS823P</b>
Metal bowl / sight gauge / twist drain kit	<b>PS835P</b>
DPI replacement kit	<b>PS781P</b>
Electronic DPI replacement kit	<b>PS764</b>
Automatic float drain kit	<b>PS506P</b>
Semi-auto drain kit	<b>PS511P</b>
Twist drain kit	<b>PS512P</b>
Push 'N' drain kit	<b>PS513P</b>
Electrical connector: 15mm, 3-pin DIN, 6 ft. cord	<b>PS2932JBP</b>
Grade 6 element (standard)	<b>PS824P</b>
Grade 10 element (optional)	<b>PS830P</b>
Mounting bracket kit	<b>PS843P</b>
Sight gauge kit	<b>PS914P</b>

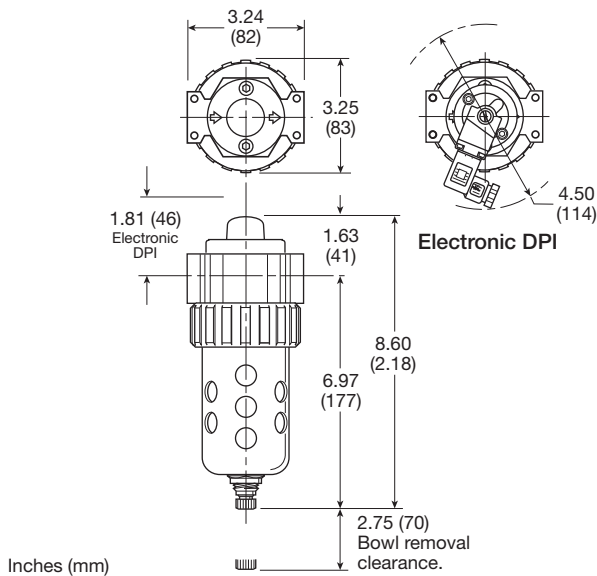

**Flow Charts**

**Grade 6 Element**

**12F 1/2" Coalescing Filter**

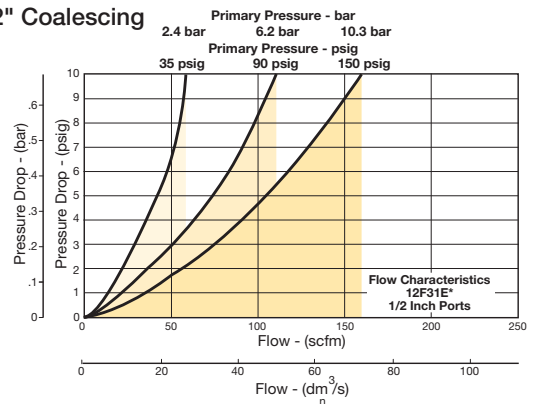

**12F 3/4" Coalescing Filter**

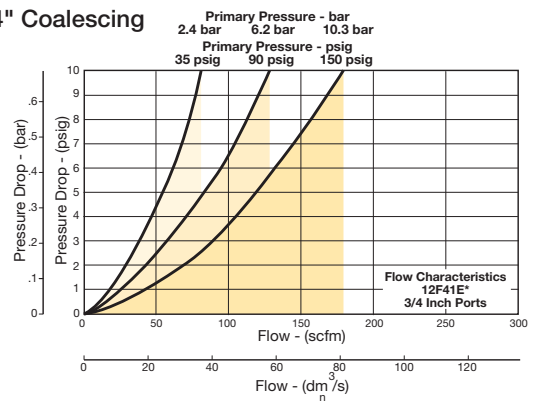

**Grade 10 Element**

**12F 1/2" Coalescing Filter**

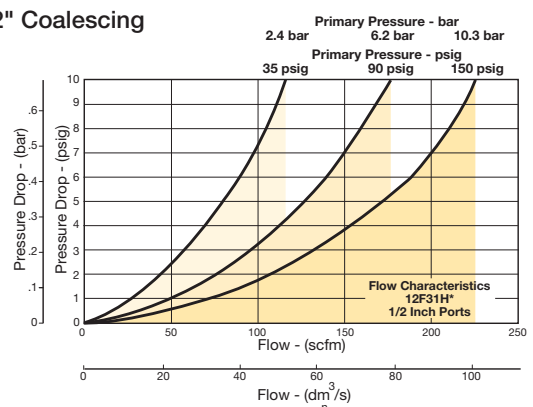

**12F 3/4" Coalescing Filter**

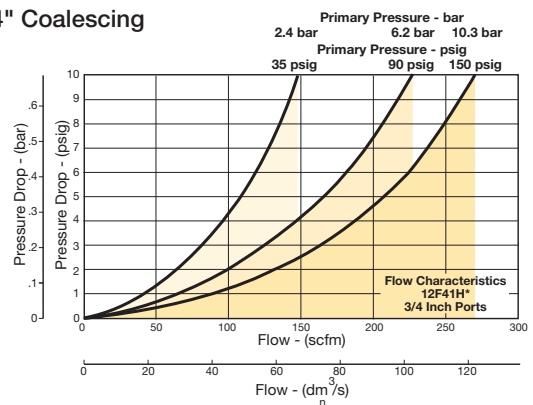

## 05R Regulators – Economy

- Secondary aspiration plus balanced poppet provides quick response and accurate pressure regulation.
- Rolling diaphragm for extended life.
- Removable non-rising knob for panel mounting and tamper resistance.
- Easily serviced.
- Reverse flow.
- 1/4", 3/8" ports (NPT)

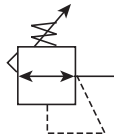

Port size	Description	Part number
1/4"	Without gauge	<b>05R113AD</b>
1/4"	With 160 psi gauge	<b>05R118AD</b>
3/8"	Without gauge	<b>05R213AD</b>
3/8"	With 160 psi gauge	<b>05R218AD</b>

NOTE: 1.53 Dia. (39 mm) hole required for panel mounting.

### Operating information

Supply pressure (max):	0 to 300 psig (0 to 20.7 bar)	
	For secondary pressure ranges see charts next page.	
Operating temperature:	32°F to 175°F (0°C to 80°C)	
Low temperature	-4°F to 125°F (-20°C to 52°C)	
Flow capacity†:		
High flow	1/4"	30 scfm (14.2 dm <sup>3</sup> /s, ANR)
	3/8"	40 scfm (18.9 dm <sup>3</sup> /s, ANR)
Gauge ports (2):	1/4 inch	
Weight:	1.1 lb (0.49 kg)	

† scfm = Standard cubic feet per minute at 100 psig inlet, 90 psig no flow secondary setting and 10 psig pressure drop.

### Ordering information:

05R
1
13
A
D

Port Size	Engineering Level
1/4 inch	D Current
3/8 inch	

Pressure Range	Relief
Without gauge	A Relieving
30 psig	
60 psig	
125 psig	
200 psig	
With gauge*	
30 psig	
60 psig	
125 psig	
200 psig	

\* Includes 1-1/2" dial face gauge.

  Most popular.

## Economy Regulators

### Material Specifications

Adjusting stem	Brass
Bonnet	Plastic
Body	Zinc
Collar, Knob	Plastic
Diaphragm	Nitrile
Poppet & cap	Plastic
Seals	Nitrile
Springs – poppet & control	Steel

### Repair and Service Kits

Bonnet assembly kit	<b>PS915P</b>
Control knob	<b>P04420</b>
1-1/2" dial face 30 psig (0 to 2.1 bar), gauge	<b>K4515N14030</b>
1-1/2" dial face 60 psig (0 to 4.1 bar), gauge	<b>K4515N14060</b>
1-1/2" dial face 160 psig (0 to 11.0 bar), gauge	<b>K4515N14160</b>
1-1/2" dial face 300 psig (0 to 20.7 bar), gauge	<b>K4515N14300</b>
2" dial face 60 psig (0 to 4.1 bar), gauge	<b>K4520N14060</b>
2" dial face 160 psig (0 to 11.0 bar), gauge	<b>K4520N14160</b>
2" dial face 300 psig (0 to 20.7 bar), gauge	<b>K4520N14300</b>
Mounting bracket kit	<b>PS963P</b>
Panel mount nut – metal	<b>PS964P</b>
1-30 psig spring	<b>P04427</b>
1-60 psig spring	<b>P04426</b>
2-125 psig spring	<b>P04425</b>
2-200 psig spring	<b>P02934</b>
Relieving service kit	<b>PS908P</b>

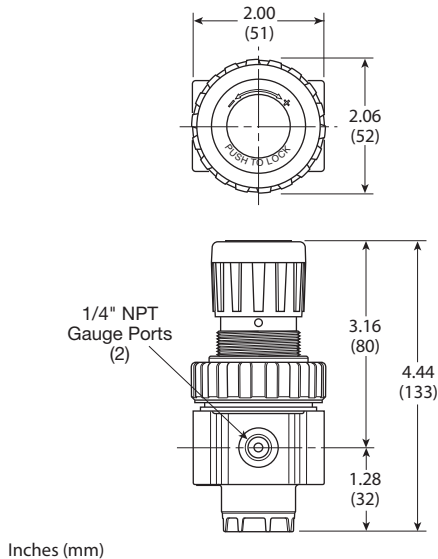

## Air Preparation Products

### Prep-Air® II Series

### Flow Charts

#### 05R 1/4" Regulator

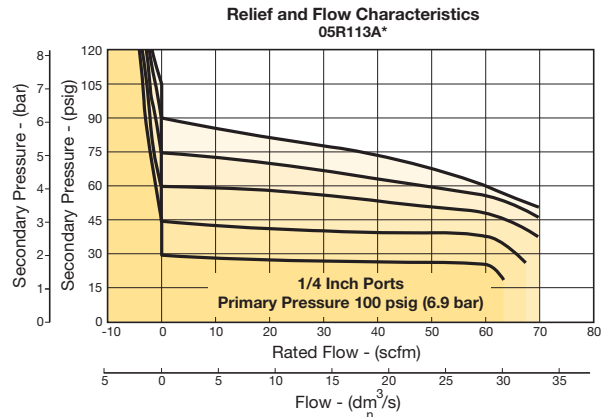

#### 05R 3/8" Regulator

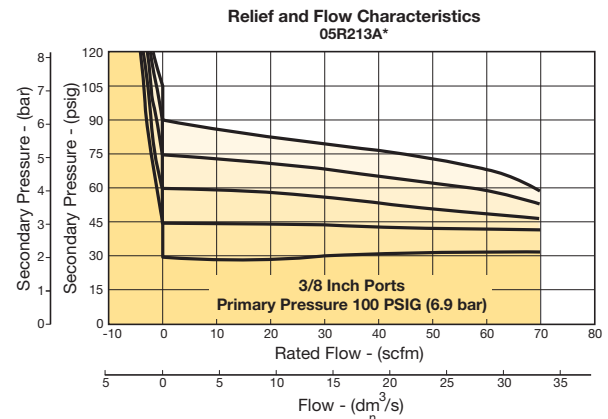

**WARNING**

Product rupture can cause serious injury.  
Do not connect regulator to bottled gas.  
Do not exceed Maximum primary pressure rating.

**CAUTION:**

**REGULATOR PRESSURE ADJUSTMENT** – The working range of knob adjustment is designed to permit outlet pressures within their full range. Pressure adjustment beyond this range is also possible because the knob is not a limiting device. This is a common characteristic of most industrial regulators, and limiting devices may be obtained only by special design. For best performance, regulated pressure should always be set by increasing the pressure up to the desired setting.

Prep-Air® II  
Products



Filters

Coalescers

Regulators

Filter /  
Regulators

Lubricators

Combinations

Accessories

## 06R Regulators – Compact

- Secondary aspiration plus balanced poppet provides quick response and accurate pressure regulation
- Rolling diaphragm for extended life
- Two high flow 1/4" gauge ports can be used as additional outlets
- Easily serviced
- Removable non-rising knob for panel mounting and tamper resistance
- 1/4", 3/8", 1/2" ports (NPT, BSPP)

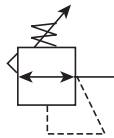

Port size	Description	Part number
1/4"	Without gauge	<b>06R113AC</b>
1/4"	With 160 psi gauge	<b>06R118AC</b>
3/8"	Without gauge	<b>06R213AC</b>
3/8"	With 160 psi gauge	<b>06R218AC</b>
1/2"	Without gauge	<b>06R313AC</b>
1/2"	With 160 psi gauge	<b>06R318AC</b>

NOTE: 2.0 Dia. (51 mm) hole required for panel mounting.

### Operating information

Supply pressure (max):	250 psig (17.2 bar)
Secondary pressure ranges:	
Standard	2 to 125 psig (0 to 8.6 bar)
Low	1 to 60 psig (0 to 4.1 bar)
High	5 to 250 psig (0.4 to 17.2 bar)
Operating temperature:	32°F to 175°F (0°C to 80°C)
Low temperature	-4°F to 125°F (-20°C to 52°C)
Flow capacity†:	
High flow	1/4" 53 scfm (25 dm³/s, ANR)
	3/8" 60 scfm (28.3 dm³/s, ANR)
	1/2" 75 scfm (35.4 dm³/s, ANR)
Gauge ports (2):	1/4 inch (can be used as additional full flow 1/4 inch outlet ports)
Weight:	1.6 lb (0.7 kg)

† scfm = Standard cubic feet per minute at 100 psig inlet, 90 psig no flow secondary setting and 10 psig pressure drop.

### Ordering information:

<b>06R</b>	<b>1</b>	<b>13</b>	<b>A</b>	<b>C</b>																																					
<table border="1"> <thead> <tr><th>Port Size</th></tr> </thead> <tbody> <tr><td>1/4 inch</td><td>1</td></tr> <tr><td>3/8 inch</td><td>2</td></tr> <tr><td>1/2 inch</td><td>3</td></tr> </tbody> </table>		Port Size	1/4 inch	1	3/8 inch	2	1/2 inch	3	<table border="1"> <thead> <tr><th>Pressure Range</th></tr> </thead> <tbody> <tr><td>Without gauge</td><td></td></tr> <tr><td>60 psig</td><td>11</td></tr> <tr><td>125 psig</td><td>13</td></tr> <tr><td>250 psig</td><td>15</td></tr> <tr><td>With gauge*</td><td></td></tr> <tr><td>60 psig</td><td>16</td></tr> <tr><td>125 psig</td><td>18</td></tr> <tr><td>250 psig</td><td>21</td></tr> </tbody> </table> <p>* Includes 1-1/2" dial face gauge.</p>		Pressure Range	Without gauge		60 psig	11	125 psig	13	250 psig	15	With gauge*		60 psig	16	125 psig	18	250 psig	21	<table border="1"> <thead> <tr><th>Relief</th></tr> </thead> <tbody> <tr><td>Relieving</td><td>A</td></tr> <tr><td>Non-relieving</td><td>L</td></tr> </tbody> </table>		Relief	Relieving	A	Non-relieving	L	<table border="1"> <thead> <tr><th>Preset / Pressure Limited</th></tr> </thead> <tbody> <tr><td>Blank</td><td>None</td></tr> <tr><td>XXX*</td><td>Preset pressure</td></tr> </tbody> </table> <p>* Available preset / pressure limited range, 10 to 90 psig in 5 psig increments. For higher pressures, contact factory. (Example: 065 = 65 psig)</p>		Preset / Pressure Limited	Blank	None	XXX*	Preset pressure
Port Size																																									
1/4 inch	1																																								
3/8 inch	2																																								
1/2 inch	3																																								
Pressure Range																																									
Without gauge																																									
60 psig	11																																								
125 psig	13																																								
250 psig	15																																								
With gauge*																																									
60 psig	16																																								
125 psig	18																																								
250 psig	21																																								
Relief																																									
Relieving	A																																								
Non-relieving	L																																								
Preset / Pressure Limited																																									
Blank	None																																								
XXX*	Preset pressure																																								
<table border="1"> <thead> <tr><th>Options</th></tr> </thead> <tbody> <tr><td>Blank</td><td>No option</td></tr> <tr><td>L†</td><td>Preset non-adjustable</td></tr> <tr><td>P†</td><td>Preset adjustable</td></tr> <tr><td>R</td><td>Reverse Flow</td></tr> </tbody> </table> <p>† Inlet Pressure is 100 psig. For other pressures, contact factory.</p>		Options	Blank	No option	L†	Preset non-adjustable	P†	Preset adjustable	R	Reverse Flow	<table border="1"> <thead> <tr><th>Port Type</th></tr> </thead> <tbody> <tr><td>Blank</td><td>NPT</td></tr> <tr><td>1*</td><td>BSPP</td></tr> </tbody> </table> <p>* 1/4 &amp; 3/8 inch meet ISO 1179-1 Standard.</p>		Port Type	Blank	NPT	1*	BSPP	<table border="1"> <thead> <tr><th>Engineering Level</th></tr> </thead> <tbody> <tr><td>Current</td><td>C</td></tr> </tbody> </table>		Engineering Level	Current	C																			
Options																																									
Blank	No option																																								
L†	Preset non-adjustable																																								
P†	Preset adjustable																																								
R	Reverse Flow																																								
Port Type																																									
Blank	NPT																																								
1*	BSPP																																								
Engineering Level																																									
Current	C																																								
<p>Spring Type by Preset / Limited Pressure:          For Preset / Limited Pressure 26 to 50 use 60 psi spring          For Preset / Limited Pressure 51 to 90 use 125 psi spring</p>																																									

Most popular.

Prep-Air® II Products  
 Filters  
 Coalescers  
 Regulators  
 Filter / Regulators  
 Lubricators  
 Combinations  
 Accessories



## Compact Regulators

### Material Specifications

Adjusting stem	Steel
Body	Zinc
Bonnet, piston stem, valve poppet & cap	Plastic
Collar, knob	Plastic
Diaphragm	Nitrile
Seals	Nitrile
Spring, poppet	Stainless
Spring, control	Steel

### Repair and Service Kits

Bonnet assembly kit	<b>PS715P</b>
Control knob	<b>P04069B</b>
2" dial face 60 psig (0 to 4.1 bar), gauge	<b>K4520N14060</b>
2" dial face 160 psig (0 to 11.0 bar), gauge	<b>K4520N14160</b>
2" dial face 300 psig (0 to 20.7 bar), gauge	<b>K4520N14300</b>
1-3/4" digital round face 160 psig (0 to 11.0 bar) gauge	<b>K4517N14160D</b>
Mounting bracket kit (includes panel mount nut)	<b>PS707P</b>
Panel mount nut, plastic	<b>P04082</b>
Panel mount nut, metal	<b>P04079B</b>
Reverse flow service conversion kit, relieving	<b>PS708RP</b>
Relieving (includes poppet)	<b>PS708P</b>
Non-relieving (includes poppet)	<b>PS709P</b>
1-30 psig spring	<b>P01698</b>
1-60 psig spring	<b>P04062</b>
2-125 psig spring	<b>P04063</b>
5-250 psig spring	<b>P04064</b>
Tamperproof kit	<b>PS737P</b>

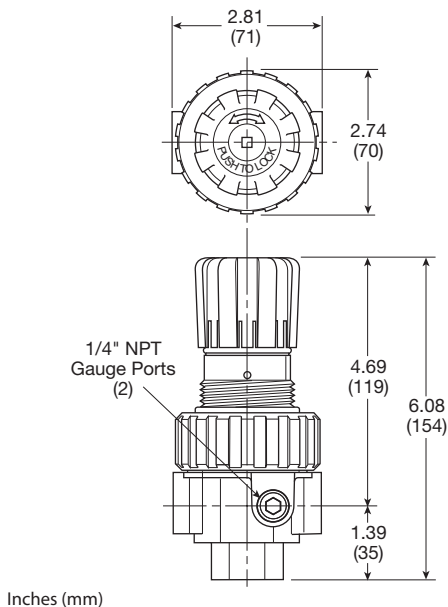

Inches (mm)

## Air Preparation Products Prep-Air® II Series

### Flow Charts

#### 06R 1/4" Regulator

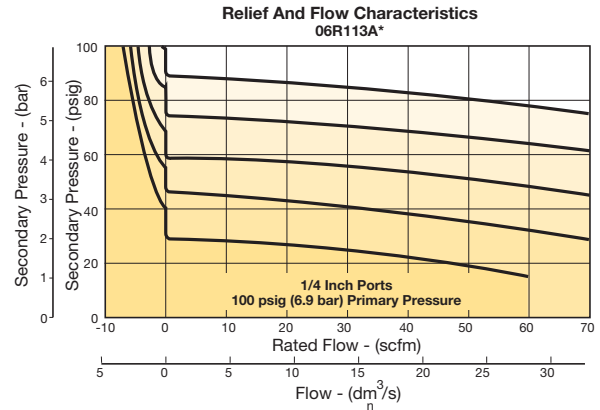

#### 06R 3/8" Regulator

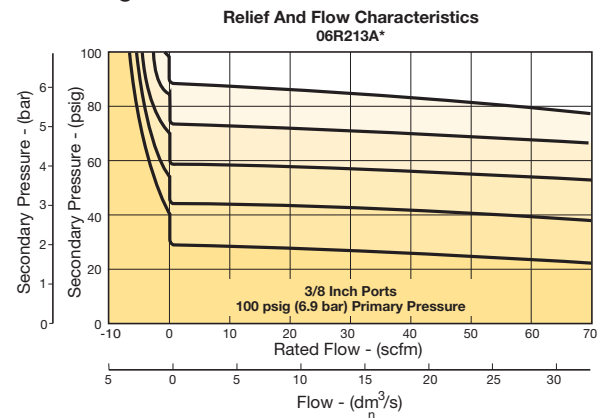

#### 06R 1/2" Regulator

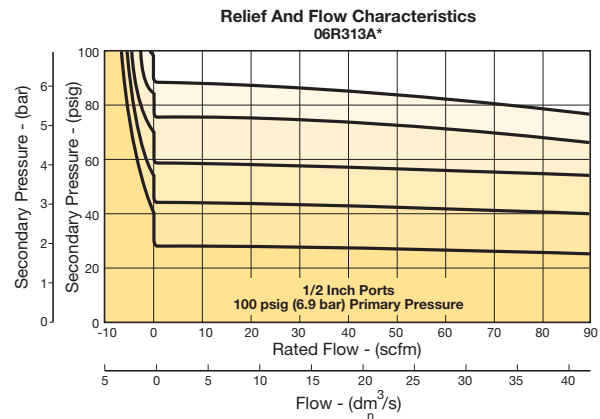

### WARNING

Product rupture can cause serious injury.  
Do not connect regulator to bottled gas.  
Do not exceed Maximum primary pressure rating.

### CAUTION:

**REGULATOR PRESSURE ADJUSTMENT** – The working range of knob adjustment is designed to permit outlet pressures within their full range. Pressure adjustment beyond this range is also possible because the knob is not a limiting device. This is a common characteristic of most industrial regulators, and limiting devices may be obtained only by special design. For best performance, regulated pressure should always be set by increasing the pressure up to the desired setting.

Prep-Air® II  
Products



Filters

Coalescers

Regulators

Filter /  
Regulators

Lubricators

Combinations

Accessories

## 07R Regulators – Standard

- Secondary aspiration plus balanced poppet provides quick response and accurate pressure regulation
- Rolling diaphragm for extended life
- Two high flow 1/4" gauge ports can be used as additional outlets
- Easily serviced
- Removable non-rising knob for panel mounting and tamper resistance
- 1/2", 3/4" ports (NPT, BSPP)

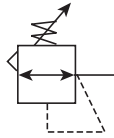

Port size	Description	Part number
1/2"	Without gauge	<b>07R313AC</b>
1/2"	With 160 psi gauge	<b>07R318AC</b>
3/4"	Without gauge	<b>07R413AC</b>
3/4"	With 160 psi gauge	<b>07R418AC</b>

NOTE: 2.0 Dia. (51 mm) hole required for panel mounting.

### Operating information

Supply pressure (max):	250 psig (17.2 bar)	
Secondary pressure ranges:		
Standard	2 to 125 psig (0 to 8.6 bar)	
Low	1 to 60 psig (0 to 4.1 bar)	
High	5 to 250 psig (0.4 to 17.2 bar)	
Operating temperature:	32°F to 175°F (0°C to 80°C)	
Low temperature	-4°F to 125°F (-20°C to 52°C)	
Flow capacity†:		
High flow	1/2"	90 scfm (42.5 dm <sup>3</sup> /s, ANR)
	3/4"	90 scfm (42.5 dm <sup>3</sup> /s, ANR)
Gauge ports (2):	1/4 inch (can be used as additional full flow 1/4 inch outlet ports)	
Weight:	2.5 lb (1.1 kg)	

† scfm = Standard cubic feet per minute at 100 psig inlet, 90 psig no flow secondary setting and 10 psig pressure drop.

### Ordering information:

07R
3
13
A
C

Port Size	
1/2 inch	3
3/4 inch	4

Pressure Range	
Without gauge	
60 psig	11
125 psig	13
250 psig	15
With gauge*	
60 psig	16
125 psig	18
250 psig	21

\* Includes 1-1/2" dial face gauge.

Preset / Pressure Limited	
Blank	None
XXX*	Preset pressure

\* Available preset / pressure limited range, 10 to 90 psig in 5 psig increments. For higher pressures, contact factory.  
(Example: 065 = 65 psig)

Relief	
Relieving	A
Non-relieving	L

Port Type	
Blank	NPT
1*	BSPP

\* 1/4 & 3/8 inch meet ISO 1179-1 Standard.

Options	
Blank	No option
L †	Preset non-adjustable
P †	Preset Adjustable
R	Reverse Flow

† Inlet Pressure is 100 psig. For other pressures, contact factory.

Engineering Level	
Current	C

Spring Type by Preset / Limited Pressure:  
 For Preset / Limited Pressure 26 to 50 use 60 psi spring  
 For Preset / Limited Pressure 51 to 90 use 125 psi spring

□ Most popular.

Prep-Air® II Products  
 Filters  
 Coalescers  
 Regulators  
 Filter / Regulators  
 Lubricators  
 Combinations  
 Accessories



## Standard Regulators

### Material Specifications

Adjusting stem	Steel
Body	Zinc
Bonnet, piston stem, valve poppet & cap	Plastic
Collar, knob	Plastic
Diaphragm	Nitrile
Seals	Nitrile
Spring, poppet	Stainless
Spring, control	Steel

### Repair and Service Kits

Bonnet assembly kit	<b>PS715P</b>
Control knob	<b>P04069B</b>
2" dial face 60 psig (0 to 4.1 bar), gauge	<b>K4520N14060</b>
2" dial face 160 psig (0 to 11.0 bar), gauge	<b>K4520N14160</b>
2" dial face 300 psig (0 to 20.7 bar), gauge	<b>K4520N14300</b>
1-3/4" digital round face 160 psig (0 to 11.0 bar), gauge	<b>K4517N14160D</b>
Mounting bracket kit (includes panel mount nut)	<b>PS807P</b>
Panel mount nut, plastic	<b>P04082</b>
Panel Mount nut, metal	<b>P04079B</b>
Reverse flow service conversion kit, relieving	<b>PS808RP</b>
Relieving (includes poppet)	<b>PS808P</b>
Non-relieving (includes poppet)	<b>PS809P</b>
1-30 psig spring	<b>P01698</b>
1-60 psig spring	<b>P04062</b>
2-125 psig spring	<b>P04063</b>
5-250 psig spring	<b>P04064</b>
Tamperproof kit	<b>PS737P</b>

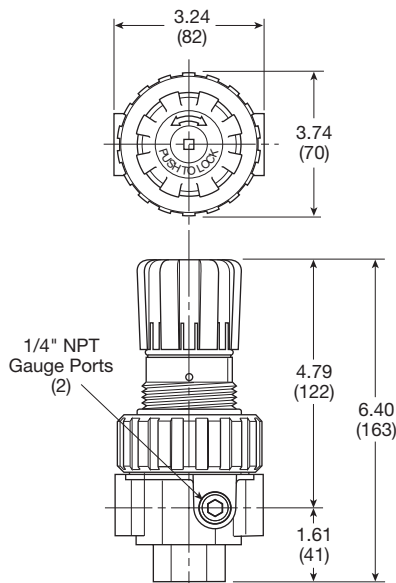

Inches (mm)

## Air Preparation Products Prep-Air® II Series

### Flow Charts

#### 07R 1/2" Regulator

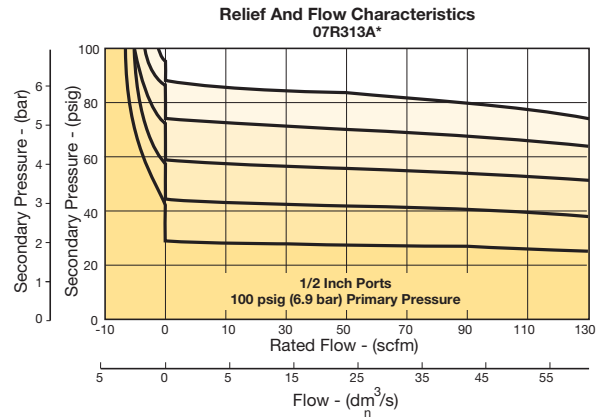

#### 07R 3/4" Regulator

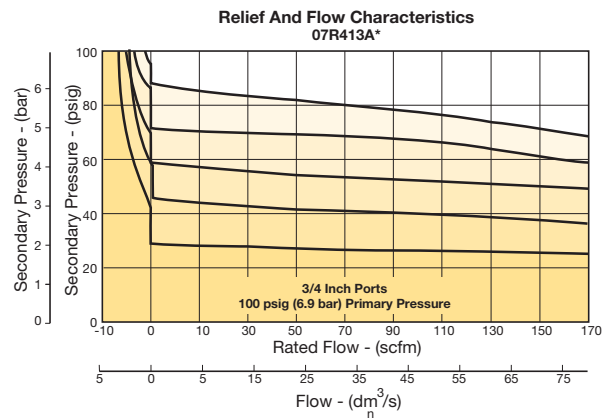

**⚠ WARNING**  
**Product rupture can cause serious injury.**  
**Do not connect regulator to bottled gas.**  
**Do not exceed Maximum primary pressure rating.**

### CAUTION:

**REGULATOR PRESSURE ADJUSTMENT** – The working range of knob adjustment is designed to permit outlet pressures within their full range. Pressure adjustment beyond this range is also possible because the knob is not a limiting device. This is a common characteristic of most industrial regulators, and limiting devices may be obtained only by special design. For best performance, regulated pressure should always be set by increasing the pressure up to the desired setting.

Prep-Air® II Products
<b>F</b>
Filters
Coalescers
Regulators
Filter / Regulators
Lubricators
Combinations
Accessories



## 11R Pilot Controlled Regulator – Compact

- Balanced poppet provides quick response and accurate pressure regulation
- Pilot controlled regulators can be mounted “out of reach” with pilot regulator installed in a convenient location
- Solid control piston for extended life
- Two full flow 1/4" gauge ports can be used as additional outlets
- Pilot port 1/4 Inch
- 1/4", 3/8", 1/2" ports (NPT, BSPP)

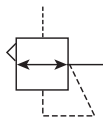

Port size	Description	Part number
1/4"	Without gauge	<b>11R115PC</b>
1/4"	With 160 psi gauge	<b>11R121PC</b>
3/8"	Without gauge	<b>11R215PC</b>
3/8"	With 160 psi gauge	<b>11R221PC</b>
1/2"	Without gauge	<b>11R315PC</b>
1/2"	With 160 psi gauge	<b>11R321PC</b>

NOTE: 2.0 Dia. (51 mm) hole required for panel mounting.

### Operating information

Supply pressure (max):	0 to 250 psig (0 to 17.2 bar)	
Operating temperature:	32°F to 175°F (0°C to 80°C)	
Flow capacity†:		
High flow	1/4"	85 scfm (40 dm <sup>3</sup> /s, ANR)
	3/8"	95 scfm (44.8 dm <sup>3</sup> /s, ANR)
	1/2"	95 scfm (44.8 dm <sup>3</sup> /s, ANR)
Gauge ports (2):	1/4 inch (can be used as additional full flow 1/4 inch outlet ports)	
Weight:	1.3 lb (0.53 kg)	

† scfm = Standard cubic feet per minute at 100 psig inlet, 90 psig no flow secondary setting and 10 psig pressure drop.

### Ordering information:

<b>11R</b>	<b>2</b>	<b>15</b>	<b>P</b>	<b>C</b>	<b>1</b>																									
<table border="1"> <thead> <tr><th>Port Threads</th></tr> </thead> <tbody> <tr><td>1/4 inch</td><td>1</td></tr> <tr><td>3/8 inch</td><td>2</td></tr> <tr><td>1/2 inch</td><td>3</td></tr> </tbody> </table>		Port Threads	1/4 inch	1	3/8 inch	2	1/2 inch	3	<table border="1"> <thead> <tr><th>Relief / Gauge Options</th></tr> </thead> <tbody> <tr><td>Without gauge</td><td></td></tr> <tr><td>Non-relieving piston</td><td>14</td></tr> <tr><td>Relieving piston</td><td>15</td></tr> <tr><td>With gauge *</td><td></td></tr> <tr><td>Non-relieving piston</td><td>19</td></tr> <tr><td>Relieving piston</td><td>21</td></tr> </tbody> </table>		Relief / Gauge Options	Without gauge		Non-relieving piston	14	Relieving piston	15	With gauge *		Non-relieving piston	19	Relieving piston	21	<table border="1"> <thead> <tr><th>Port Type</th></tr> </thead> <tbody> <tr><td>Blank</td><td>NPT</td></tr> <tr><td>1</td><td>BSPP</td></tr> </tbody> </table>		Port Type	Blank	NPT	1	BSPP
Port Threads																														
1/4 inch	1																													
3/8 inch	2																													
1/2 inch	3																													
Relief / Gauge Options																														
Without gauge																														
Non-relieving piston	14																													
Relieving piston	15																													
With gauge *																														
Non-relieving piston	19																													
Relieving piston	21																													
Port Type																														
Blank	NPT																													
1	BSPP																													
			<table border="1"> <thead> <tr><th>Engineering Level</th></tr> </thead> <tbody> <tr><td>C</td><td>Current</td></tr> </tbody> </table>		Engineering Level	C	Current																							
Engineering Level																														
C	Current																													
			<table border="1"> <thead> <tr><th>Adjustment</th></tr> </thead> <tbody> <tr><td>P</td><td>Pilot operated</td></tr> </tbody> </table>		Adjustment	P	Pilot operated																							
Adjustment																														
P	Pilot operated																													

\* Includes 2" dial face gauge 0 to 300 psig.

Most popular.





## Compact Pilot Controlled Regulators

### Material Specifications

Body & pilot cap	Zinc
Piston, valve poppet, & collar	Plastic
Seals	Nitrile
Springs	Steel

### Repair and Service Kits

Seat Insert kit	<b>PS713P</b>
2" dial face 60 psig (0 to 4.1 bar), gauge	<b>K4520N14060</b>
2" dial face 160 psig (0 to 11.0 bar), gauge	<b>K4520N14160</b>
2" dial face 300 psig (0 to 20.7 bar), gauge	<b>K4520N14300</b>
1-3/4" digital round face 160 psig (0 to 11.0 bar), gauge	<b>K4517N14160D</b>
Mounting bracket kit (includes panel mount nut)	<b>PS707P</b>
Panel mount nut, plastic	<b>P04082</b>
Panel mount nut, metal	<b>P04079B</b>
Pilot conversion kit – relieving	<b>PS745P</b>
Non-Relieving	<b>PS747P</b>
Relieving	<b>PS749P</b>

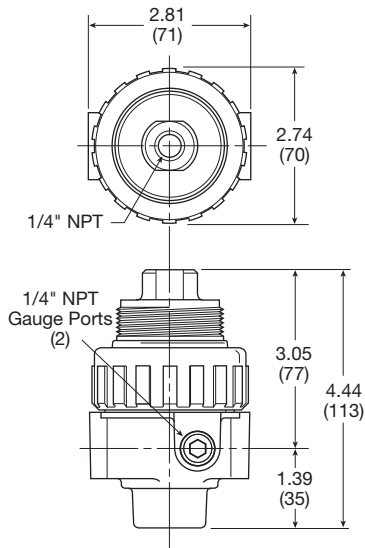

Inches (mm)

## Air Preparation Products Prep-Air® II Series

### Flow Charts

#### 11R 1/2" Regulator

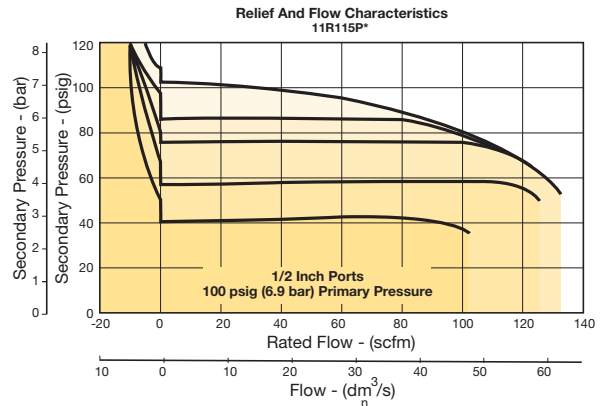

#### 11R 3/8" Regulator

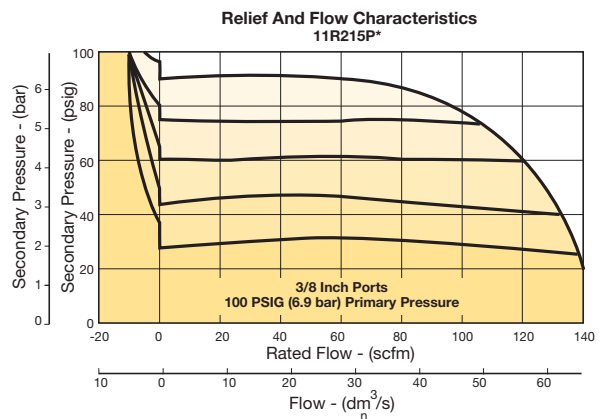

### WARNING

Product rupture can cause serious injury.  
Do not connect regulator to bottled gas.  
Do not exceed Maximum primary pressure rating.

Prep-Air® II  
Products



Filters

Coalescers

Regulators

Filter /  
Regulators

Lubricators

Combinations

Accessories

**12R Pilot Controlled Regulator – Standard**

- Balanced poppet provides quick response and accurate pressure regulation
- Pilot controlled regulators can be mounted “out of reach” with pilot regulator installed in a convenient location
- Solid control piston for extended life
- Two full flow 1/4" gauge ports can be used as additional outlets
- Pilot port 1/4 Inch
- 1/2", 3/4" ports (NPT, BSPP)

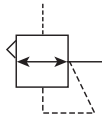

**Operating information**

Supply pressure (max):	0 to 250 psig (0 to 17.2 bar)	
Operating temperature:	32°F to 175°F (0°C to 80°C)	
Flow capacity†:		
High flow	1/2"	140 scfm (66 dm <sup>3</sup> /s, ANR)
	3/4"	140 scfm (66 dm <sup>3</sup> /s, ANR)
Gauge ports (2):	1/4 inch (can be used as additional full flow 1/4 inch outlet ports)	
Weight:	2.0 lb (0.91 kg)	

† scfm = Standard cubic feet per minute at 100 psig inlet, 90 psig no flow secondary setting and 10 psig pressure drop.

Port size	Description	Part number
1/2"	Without gauge	<b>12R315PB</b>
1/2"	With 160 psi gauge	<b>12R321PB</b>
3/4"	Without gauge	<b>12R415PB</b>
3/4"	With 160 psi gauge	<b>12R421PB</b>

NOTE: 2.0 Dia. (51 mm) hole required for panel mounting.

**Ordering information:**

<b>12R</b>	<b>3</b>	<b>15</b>	<b>P</b>	<b>B</b>	<b> </b>																										
<table border="1"> <thead> <tr><th colspan="2">Port Threads</th></tr> </thead> <tbody> <tr><td>1/2 inch</td><td>3</td></tr> <tr><td>3/4 inch</td><td>4</td></tr> </tbody> </table>		Port Threads		1/2 inch	3	3/4 inch	4	<table border="1"> <thead> <tr><th colspan="2">Relief / Gauge Options</th></tr> </thead> <tbody> <tr><td>Without gauge</td><td></td></tr> <tr><td>Non-relieving piston</td><td>14</td></tr> <tr><td>Relieving piston</td><td>15</td></tr> <tr><td>With gauge *</td><td></td></tr> <tr><td>Non-relieving piston</td><td>19</td></tr> <tr><td>Relieving piston</td><td>21</td></tr> </tbody> </table>		Relief / Gauge Options		Without gauge		Non-relieving piston	14	Relieving piston	15	With gauge *		Non-relieving piston	19	Relieving piston	21	<table border="1"> <thead> <tr><th colspan="2">Port Type</th></tr> </thead> <tbody> <tr><td>Blank</td><td>NPT</td></tr> <tr><td>1</td><td>BSPP</td></tr> </tbody> </table>		Port Type		Blank	NPT	1	BSPP
Port Threads																															
1/2 inch	3																														
3/4 inch	4																														
Relief / Gauge Options																															
Without gauge																															
Non-relieving piston	14																														
Relieving piston	15																														
With gauge *																															
Non-relieving piston	19																														
Relieving piston	21																														
Port Type																															
Blank	NPT																														
1	BSPP																														
			<table border="1"> <thead> <tr><th colspan="2">Engineering Level</th></tr> </thead> <tbody> <tr><td>B</td><td>Current</td></tr> </tbody> </table>		Engineering Level		B	Current																							
Engineering Level																															
B	Current																														
			<table border="1"> <thead> <tr><th colspan="2">Adjustment</th></tr> </thead> <tbody> <tr><td>P</td><td>Pilot operated</td></tr> </tbody> </table>		Adjustment		P	Pilot operated																							
Adjustment																															
P	Pilot operated																														

\* Includes 2" dial face gauge 0 to 300 psig.

- Prep-Air® II  
Products
- U**
- Filters
- Coalescers
- Regulators
- Filter /  
Regulators
- Lubricators
- Combinations
- Accessories



## Standard Pilot Controlled Regulators

### Material Specifications

Body & pilot cap	Zinc
Piston, valve poppet, & collar	Plastic
Seals	Nitrile
Springs	Steel

### Repair and Service Kits

Seat insert kit	<b>PS813P</b>
2" dial face 60 psig (0 to 4.1 bar)	<b>K4520N14060</b>
2" dial face 160 psig (0 to 11.0 bar)	<b>K4520N14160</b>
2" dial face 300 psig (0 to 20.7 bar)	<b>K4520N14300</b>
1-3/4" digital round face 160 psig (0 to 11.0 bar)	<b>K4517N14160D</b>
Mounting bracket kit (includes panel mount nut)	<b>PS807P</b>
Panel mount nut, plastic	<b>P04082</b>
Panel mount nut, metal	<b>P04079B</b>
Pilot conversion kit – relieving	<b>PS745P</b>
Non-relieving	<b>PS847P</b>
Relieving	<b>PS849P</b>

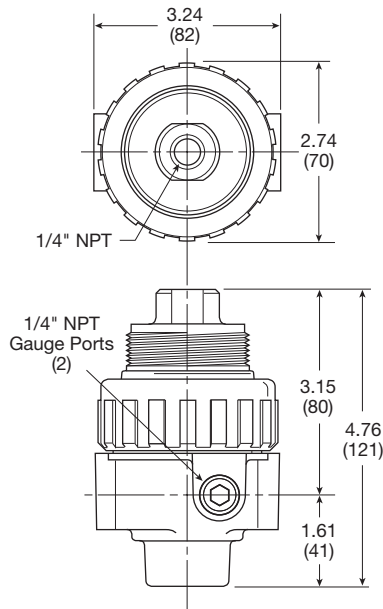

Inches (mm)

## Air Preparation Products Prep-Air® II Series

### Flow Charts

#### 12R 1/2 and 3/4" Regulator

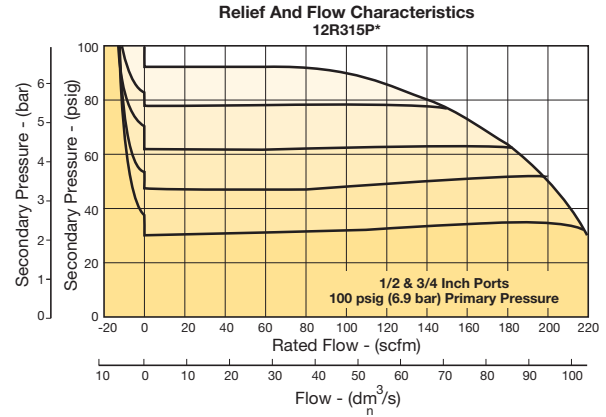

### ⚠ WARNING

Product rupture can cause serious injury.  
Do not connect regulator to bottled gas.  
Do not exceed Maximum primary pressure rating.

Prep-Air® II  
Products



Filters

Coalescers

Regulators

Filter /  
Regulators

Lubricators

Combinations

Accessories

**05E Filter / Regulator – Economy**

- Space saving package offers both filter and regulator features for optimal performance
- Excellent water removal efficiency
- Rolling diaphragm for extended life
- Removable non-rising knob for tamper resistance
- Quick response, and accurate pressure regulation regardless of changing flow or inlet pressure
- 40 micron filter element standard
- 1/4", 3/8" ports (NPT)

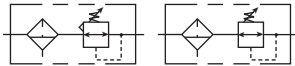

**Operating information**

Supply pressure (max):	Plastic bowl		0 to 150 psig (0 to 10.3 bar)
Operating temperature:	Plastic bowl		32°F to 125°F (0°C to 52°C)
Flow capacity†:	High flow	1/4"	30 scfm (14.2 dm³/s, ANR)
		3/8"	40 scfm (18.9 dm³/s, ANR)
Bowl capacity:	2 oz.		
Auto pulse drain tube barb	1/8 inch		
Gauge ports (2):	1/4 inch		
Sump capacity:	0.9 oz.		
Weight:	1.35 lb (0.6 kg)		

† scfm = Standard cubic feet per minute at 100 psig inlet, 90 psig no flow secondary setting and 10 psig pressure drop.

Port size	Description ‡	Part number
1/4"	Poly bowl, metal guard, twist drain	<b>05E12A13AB</b>
1/4"	Poly bowl, metal guard, auto pulse drain	<b>05E1PA13AB</b>
3/8"	Poly bowl, metal guard, twist drain	<b>05E22A13AB</b>
3/8"	Poly bowl, metal guard, auto pulse drain	<b>05E2PA13AB</b>

‡ For polycarbonate bowl, see caution in Engineering Section A.  
NOTE: 1.53 Dia. (39 mm) hole required for panel mounting.

**Ordering information:**

**05E**

Port Size	
1/4 inch	1
3/8 inch	2

**1**

**2**

Bowl Options	
Poly bowl, metal bowl guard, twist drain	2
Poly bowl, metal bowl guard, auto pulse drain	P

**A**

Element	
40 Micron	A

**13**

Pressure Range	
Without gauge	With gauge*
11 60 psig	16 60 psig
13 125 psig	18 125 psig

**A**

Relief	
A	Relieving

**B**

Engineering Level	
B	Current

\* Includes 1-1/2" dial face gauge.

Most popular.



**Material Specifications**

Adjusting stem	Steel
Body	Zinc
Bonnet, internal parts	Plastic
Transparent bowl	Polycarbonate
Bowl guard	Steel
Collar	Plastic
Diaphragm	Nitrile
Drain	Plastic
40 micron element (standard)	Plastic
5 micron element (optional)	Plastic
Adsorber element (optional)	Activated charcoal
Knob	Plastic
Seals	Nitrile
Sight gauge	Polyamide (nylon)
Springs, poppet & control	Steel

**Repair and Service Kits**

Bowl guard kit	<b>PS905P</b>
Poly bowl, automatic pulse drain	<b>PS995P</b>
Poly bowl, twist drain	<b>PS932P</b>
Auto pulse drain	<b>PS998P</b>
Twist drain	<b>PS512P</b>
40 micron element	<b>PS901P</b>
5 micron element	<b>PS902P</b>
Adsorber element	<b>PS931P</b>
Sight gauge kit	<b>PS914P</b>
1-1/2" dial face 30 psig (0 to 2.1 bar), gauge	<b>K4515N14030</b>
1-1/2" dial face 60 psig (0 to 4.1 bar), gauge	<b>K4515N14060</b>
1-1/2" dial face 160 psig (0 to 11.0 bar), gauge	<b>K4515N14160</b>
1-1/2" dial face 300 psig (0 to 20.7 bar), gauge	<b>K4515N14300</b>
2" dial face 60 psig (0 to 4.1 bar), gauge	<b>K4520N14060</b>
2" dial face 160 psig (0 to 11.0 bar), gauge	<b>K4520N14160</b>
2" dial face 300 psig (0 to 20.7 bar), gauge	<b>K4520N14300</b>
Mounting bracket kit (includes panel mount nut)	<b>PS963P</b>
Panel mount nut – metal	<b>PS964P</b>
1-30 psig spring	<b>P04427</b>
1-60 psig spring	<b>P04426</b>
2-125 psig spring	<b>P04425</b>
2-200 psig spring	<b>P02934</b>
Relieving service kit	<b>PS908P</b>
Bonnet assembly kit	<b>PS915P</b>

**WARNING**

**Product rupture can cause serious injury. Do not connect regulator to bottled gas. Do not exceed Maximum primary pressure rating.**

**CAUTION:**

**REGULATOR PRESSURE ADJUSTMENT** – The working range of knob adjustment is designed to permit outlet pressures within their full range. Pressure adjustment beyond this range is also possible because the knob is not a limiting device. This is a common characteristic of most industrial regulators, and limiting devices may be obtained only by special design. For best performance, regulated pressure should always be set by increasing the pressure up to the desired setting.

**Flow Charts**

**05E 1/4" Filter / Regulator**

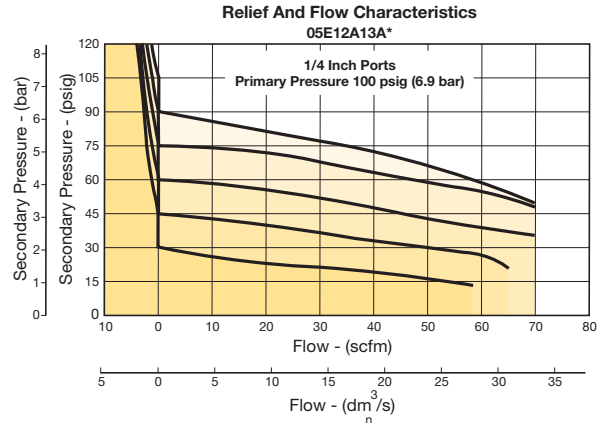

**05E 3/8" Filter / Regulator**

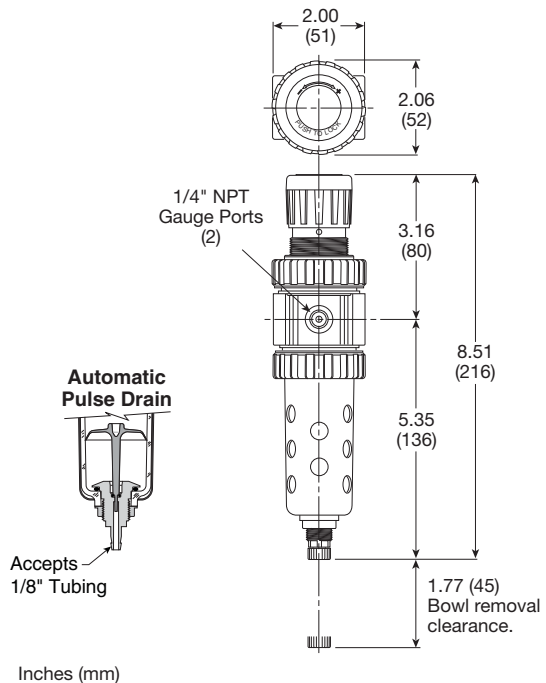
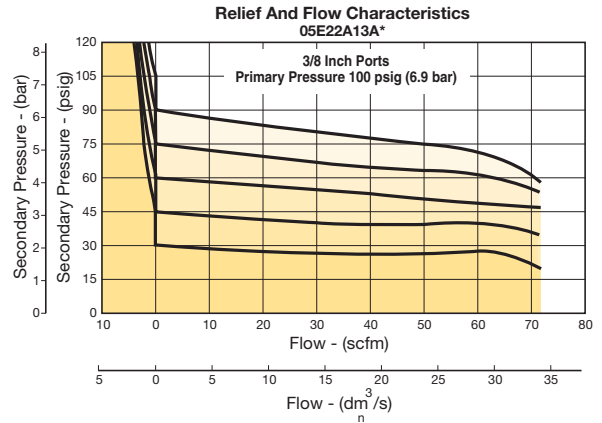

**06E Filter / Regulator – Compact**

- Space saving package offers both filter and regulator features for optimal performance
- Excellent water removal efficiency
- Rolling diaphragm for extended life
- Quick response, and accurate pressure regulation regardless of changing flow or inlet pressure
- Two high flow 1/4" gauge ports can be used as additional outlets
- Shown with recommended metal bowl guard
- 1/4", 3/8", 1/2" ports (NPT, BSPP)

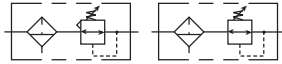

Port size	Description †	Part number
1/4"	Poly bowl, metal guard, twist drain	<b>06E12A13AC</b>
1/4"	Poly bowl, metal guard, auto float drain	<b>06E16A13AC</b>
1/4"	Metal bowl, sight gauge, twist drain	<b>06E14A13AC</b>
1/4"	Metal bowl, sight gauge, auto float drain	<b>06E18A13AC</b>
3/8"	Poly bowl, metal guard, twist drain	<b>06E22A13AC</b>
3/8"	Poly bowl, metal guard, auto float drain	<b>06E26A13AC</b>
3/8"	Metal bowl, sight gauge, twist drain	<b>06E24A13AC</b>
3/8"	Metal bowl, sight gauge, auto float drain	<b>06E28A13AC</b>
1/2"	Poly bowl, metal guard, twist drain	<b>06E32A13AC</b>
1/2"	Poly bowl, metal guard, auto float drain	<b>06E36A13AC</b>
1/2"	Metal bowl, sight gauge, twist drain	<b>06E34A13AC</b>
1/2"	Metal bowl, sight gauge, auto float drain	<b>06E38A13AC</b>

† For polycarbonate bowl, see caution in Engineering Section A.  
NOTE: 2.0 Dia. (50.8 mm) hole required for panel mounting. Max panel thickness 1/4"

**Operating information**

Supply pressure (max):	
Plastic bowl	0 to 150 psig (0 to 10.3 bar)
Metal bowl	0 to 250 psig (0 to 17.2 bar)
Auto float drain	15 to 250 psig (1.0 to 17.2 bar)
Operating temperature:	
Plastic bowl	32°F to 125°F (0°C to 52°C)
Metal bowl	32°F to 175°F (0°C to 80°C)
Secondary pressure range:	
Standard	2 to 125 psig (0 to 8.6 bar)
Low	1 to 60 psig (0 to 4.1 bar)
High	5 to 250 psig (0.4 to 17.2 bar)
Flow capacity†:	
High flow	1/4" 45 scfm (21.7 dm <sup>3</sup> /s, ANR)
	3/8" 55 scfm (26 dm <sup>3</sup> /s, ANR)
	1/2" 61 scfm (28.8 dm <sup>3</sup> /s, ANR)
Bowl capacity:	4.4 oz.
Gauge ports (2):	1/4 inch (can be used as additional full flow 1/4" outlet ports)
Sump capacity:	1.75 oz.
Weight:	1.6 lb (0.7 kg)

† scfm = Standard cubic feet per minute at 100 psig inlet, 90 psig no flow secondary setting and 10 psig pressure drop.

**Ordering information:**

**06E 1 2 A 13 A C**

Port Size	Option
1/4 inch	1
3/8 inch	2
1/2 inch	3

Bowl Options	
Poly bowl, metal bowl guard, twist drain	2
Poly bowl, metal bowl guard, auto float drain	6
Metal bowl, twist drain	3
Metal bowl, sight gauge, twist drain	4
Metal bowl, auto float drain	7
Metal bowl, sight gauge, auto float drain	8

Engineering Level	
C	Current

Relief	
A	Relieving
L	Non-relieving

Pressure Range			
Without gauge		With gauge	
11	60 psig	16	60 psig
13	125 psig	18	125 psig
15*	250 psig	21*	250 psig

Preset / Pressure Limited	
Blank	None
XXX*	Preset pressure
XXX*	Pressure limited

\* Available preset range, 10 to 90 psig in 5 psig increments. For higher pressures, contact factory. (Example: 065 = 65 psig)

Options	
Blank	No options
L †	Preset non-adjustable
P †	Preset adjustable

† Inlet Pressure is 100 psig. For other pressures, contact factory.

Port Type	
Blank	NPT
1*	BSPP

\* 1/4 & 3/8 inch meet ISO 1179-1 standard.

Spring Type by Preset / Limited Pressure:  
For Preset / Limited Pressure 26 to 50 use 60 psi spring  
For Preset / Limited Pressure 51 to 90 use 125 psi spring

Element  
40 Micron A  
5 Micron B

† Most popular.

Prep-Air® II Products  
 Filters  
 Coalescers  
 Regulators  
 Filter / Regulators  
 Lubricators  
 Combinations  
 Accessories



**Material Specifications**

Adjusting stem	Steel
Body	Zinc
Bonnet, internal parts	Plastic
Transparent bowl	Polycarbonate
Metal bowl (with or without sight gauge)	Zinc
Bowl guard	Steel
Collar	Plastic
Diaphragm	Nitrile
Manual twist drain, standard, body & nut	Plastic
Auto float drain, housing, float	Plastic
Auto float drain, seals	Nitrile
Auto float drain, springs, push rod	Stainless steel
Knob	Plastic
40 micron element (standard)	Plastic
5 micron element (optional)	Plastic
Adsorber element (optional)	Activated charcoal
Seals	Nitrile
Sight gauge	Polyamide
Poppet, spring	Stainless
Control, spring	Steel

**Repair and Service Kits**

Bonnet assembly kit	<b>PS715P</b>
Bowl guard kit	<b>PS705P</b>
Poly bowl, auto float drain	<b>PS722P</b>
Poly bowl, twist drain	<b>PS732P</b>
Metal bowl, auto float drain	<b>PS726P</b>
Metal bowl, twist drain	<b>PS734P</b>
Metal bowl, sight gauge / auto drain	<b>PS723P</b>
Metal bowl, sight gauge / twist drain	<b>PS735P</b>
Control knob	<b>P04069B</b>
Auto float drain	<b>PS506P</b>
Semi-auto drain	<b>PS511P</b>
Twist drain	<b>PS512P</b>
40 micron element	<b>PS701P</b>
5 micron element	<b>PS702P</b>
Adsorber element	<b>PS731P</b>
2" dial face 60 psig (0 to 4.1 bar), gauge	<b>K4520N14060</b>
2" dial face 160 psig (0 to 11.0 bar), gauge	<b>K4520N14160</b>
2" dial face 300 psig (0 to 20.7 bar), gauge	<b>K4520N14300</b>
1-3/4" digital round face 160 psig (0 to 11.0 bar), gauge	<b>K4517N14160D</b>
Mounting bracket kit (includes panel mount nut)	<b>PS707P</b>
Panel mount nut	<b>P04082</b>
Non-relieving (includes poppet)	<b>PS711P</b>
Relieving (includes poppet)	<b>PS710P</b>
Seat insert kit	<b>PS713P</b>
1- 30 psig spring	<b>P01698</b>
1- 60 psig spring	<b>P04062</b>
2- 125 psig spring	<b>P04063</b>
5- 250 psig spring	<b>P04064</b>
Tamperproof kit (key lock)	<b>PS737P</b>

**WARNING**

**Product rupture can cause serious injury.  
Do not connect regulator to bottled gas.  
Do not exceed Maximum primary pressure rating.**

**Flow Charts**

**06E 1/4" Filter / Regulator**

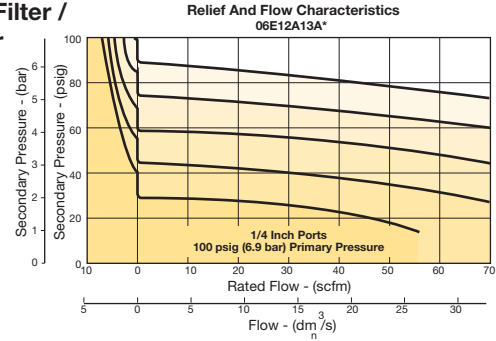

**06E 3/8" Filter / Regulator**

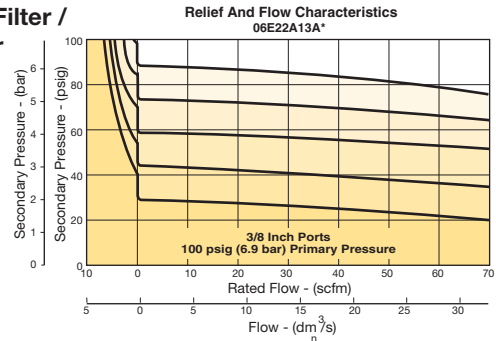

**06E 1/2" Filter / Regulator**

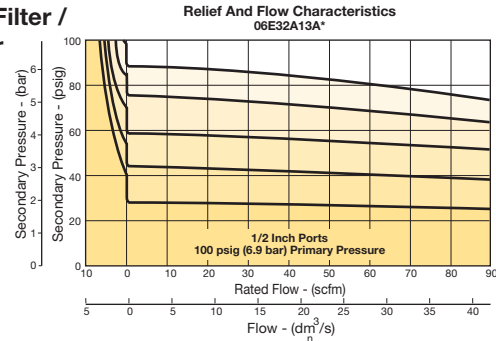

**CAUTION:**

**REGULATOR PRESSURE ADJUSTMENT** – The working range of knob adjustment is designed to permit outlet pressures within their full range. Pressure adjustment beyond this range is also possible because the knob is not a limiting device. This is a common characteristic of most industrial regulators, and limiting devices may be obtained only by special design. For best performance, regulated pressure should always be set by increasing the pressure up to the desired setting.

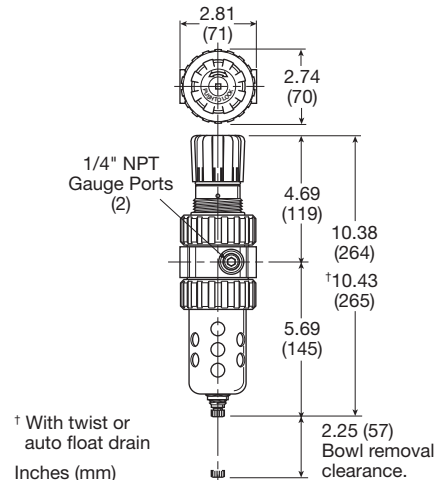

† With twist or auto float drain  
Inches (mm)





**07E Filter / Regulator – Standard**

- Space saving package offers both filter and regulator features for optimal performance
- Excellent water removal efficiency
- Rolling diaphragm for extended life
- Quick response, and accurate pressure regulation regardless of changing flow or inlet pressure
- Two high flow 1/4" gauge ports can be used as additional outlets
- Shown with recommended metal bowl guard
- 1/2", 3/4" ports (NPT, BSPP)

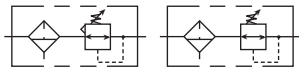

Port size	Description †	Part number
1/2"	Poly bowl, metal guard, twist drain	<b>07E32A13AC</b>
1/2"	Poly bowl, metal guard, auto float drain	<b>07E36A13AC</b>
1/2"	Metal bowl, sight gauge, twist drain	<b>07E34A13AC</b>
1/2"	Metal bowl, sight gauge, auto float drain	<b>07E38A13AC</b>
3/4"	Poly bowl, metal guard, twist drain	<b>07E42A13AC</b>
3/4"	Poly bowl, metal guard, auto float drain	<b>07E46A13AC</b>
3/4"	Metal bowl, sight gauge, twist drain	<b>07E44A13AC</b>
3/4"	Metal bowl, sight gauge, auto float drain	<b>07E48A13AC</b>

† For polycarbonate bowl, see caution in Engineering Section A.  
NOTE: 2.0 Dia. (50.8 mm) hole required for panel mounting. Max panel thickness 1/4".

**Operating information**

Supply pressure (max):		
Plastic bowl		0 to 150 psig (0 to 10.3 bar)
Metal bowl		0 to 250 psig (0 to 17.2 bar)
Auto float drain		15 to 250 psig (1.0 to 17.2 bar)
Operating temperature:		
Plastic bowl		32°F to 125°F (0°C to 52°C)
Metal bowl		32°F to 175°F (0°C to 80°C)
Secondary pressure range:		
Standard		2 to 125 psig (0 to 8.6 bar)
Low		1 to 60 psig (0 to 4.1 bar)
High		5 to 250 psig (0.4 to 17.2 bar)
Flow capacity†:		
High flow	1/2"	90 scfm (42.5 dm <sup>3</sup> /s, ANR)
	3/4"	90 scfm (42.5 dm <sup>3</sup> /s, ANR)
Bowl capacity:		7.2 oz.
Gauge ports (2):		1/4 inch (can be used as additional full flow 1/4" outlet ports)
Sump capacity:		2.8 oz.
Weight:		2.5 lb (1.1 kg)

† scfm = Standard cubic feet per minute at 100 psig inlet, 90 psig no flow secondary setting and 10 psig pressure drop.

**Ordering information:**

<b>07E</b>	<b>3</b>	<b>2</b>	<b>A</b>	<b>13</b>	<b>A</b>	<b>C</b>			
<b>Port Size</b>						<b>Engineering Level</b>			<b>Preset / Pressure Limited</b>
1/2 inch	3					C	Current		Blank
3/4 inch	4								None
									XXX*
									Preset pressure
									XXX*
									Pressure limited
									* Available preset range, 10 to 90 psig in 5 psig increments. For higher pressures, contact factory. (Example: 065 = 65 psig)
									<b>Options</b>
									Blank
									No options
									L †
									Preset non-adjustable
									P †
									Preset adjustable
									† Inlet Pressure is 100 psig. For other pressures, contact factory.
									<b>Port Type</b>
									Blank
									NPT
									1*
									BSPP
									* 1/2 & 3/4 inch meet ISO 1179-1 standard.

Bowl Options	
Poly bowl, metal bowl guard, twist drain	2
Poly bowl, metal bowl guard, auto float drain	6
Metal bowl, twist drain	3
Metal bowl, sight gauge, twist drain	4
Metal bowl, auto float drain	7
Metal bowl, sight gauge, auto float drain	8

Element	
40 Micron	A
5 Micron	B

Pressure Range			
Without gauge		With gauge	
11	60 psig	16	60 psig
13	125 psig	18	125 psig
15*	250 psig	21*	250 psig

\* If 250 psig spring range is used, use metal bowl.

Spring Type by Preset / Limited Pressure:  
For Preset / Limited Pressure 26 to 50 use 60 psi spring  
For Preset / Limited Pressure 51 to 90 use 125 psi spring

Most popular.

Prep-Air® II Products  
 Filters  
 Coalescers  
 Regulators  
 Filter / Regulators  
 Lubricators  
 Combinations  
 Accessories





**Material Specifications**

Adjusting stem	Steel
Body	Zinc
Bonnet, internal parts	Plastic
Transparent bowl	Polycarbonate
Metal bowl (with or without sight gauge)	Zinc
Bowl guard	Steel
Collar	Plastic or metal
Diaphragm	Nitrile
Manual twist drain, standard, body & nut	Plastic
Auto float drain, housing, float	Plastic
Auto float drain, seals	Nitrile
Auto float drain, springs, push rod	Stainless steel
Knob	Plastic
40 micron element (standard)	Plastic
5 micron element (optional)	Plastic
Adsorber element (optional)	Activated charcoal
Seals	Nitrile
Sight gauge	Polyamide
Poppet, spring	Stainless
Control, spring	Steel

**Repair and Service Kits**

Bonnet assembly kit	<b>PS715P</b>
Bowl guard kit	<b>PS805P</b>
Poly bowl, auto float drain	<b>PS822P</b>
Poly bowl, twist drain	<b>PS832P</b>
Metal bowl, automatic float drain	<b>PS826P</b>
Metal bowl, twist drain	<b>PS834P</b>
Metal bowl, sight gauge / auto drain	<b>PS823P</b>
Metal bowl, sight gauge / twist drain	<b>PS835P</b>
Control knob	<b>P04069B</b>
Auto float drain	<b>PS506P</b>
Twist drain	<b>PS512P</b>
40 micron element	<b>PS801P</b>
5 micron element	<b>PS802P</b>
Adsorber element	<b>PS831P</b>
2" dial face 60 psig (0 to 4.1 bar), gauge	<b>K4520N14060</b>
2" dial face 160 psig (0 to 11.0 bar), gauge	<b>K4520N14160</b>
2" dial face 300 psig (0 to 20.7 bar), gauge	<b>K4520N14300</b>
1-3/4" Digital Round Face 160 psig (0 to 11.0 bar)	<b>K4517N14160D</b>
Mounting bracket kit (includes panel mount nut)	<b>PS807P</b>
Panel mount nut	<b>P04082</b>
Non-relieving (includes poppet)	<b>PS811P</b>
Relieving (includes poppet)	<b>PS810P</b>
Seat insert kit	<b>PS813P</b>
1- 30 psig spring	<b>P01698</b>
1- 60 psig spring	<b>P04062</b>
2- 125 psig spring	<b>P04063</b>
5- 250 psig spring	<b>P04064</b>
Tamperproof kit (key lock)	<b>PS737P</b>

**Flow Charts**

**07E 1/2" Filter / Regulator**

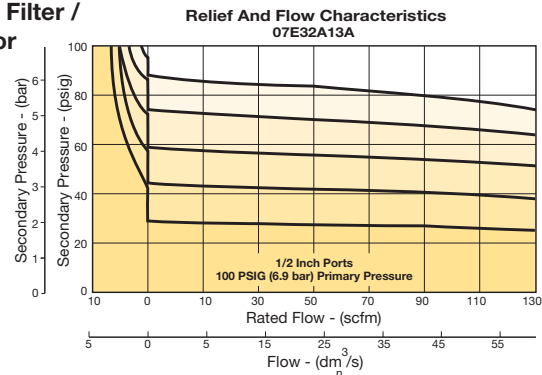

**07E 3/4" Filter / Regulator**

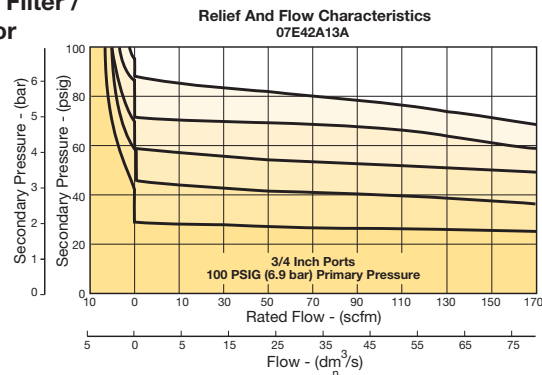

**WARNING**  
 Product rupture can cause serious injury.  
 Do not connect regulator to bottled gas.  
 Do not exceed Maximum primary pressure rating.

**CAUTION:**  
**REGULATOR PRESSURE ADJUSTMENT** – The working range of knob adjustment is designed to permit outlet pressures within their full range. Pressure adjustment beyond this range is also possible because the knob is not a limiting device. This is a common characteristic of most industrial regulators, and limiting devices may be obtained only by special design. For best performance, regulated pressure should always be set by increasing the pressure up to the desired setting.

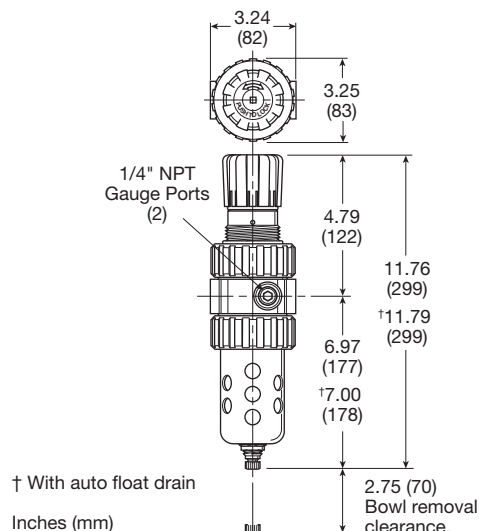

Prep-Air® II Products

Filters

Coalescers

Regulators

Filter / Regulators

Lubricators

Combinations

Accessories



**12E Filter / Regulator – Coalescing**

- Space saving package offers both coalescer and regulator features for optimal performance
- Removes liquid, aerosol and sub-micron particles
- Rolling diaphragm for extended life
- Removable non-rising knob for panel mounting and tamper resistance
- Quick response, and accurate pressure regulation regardless of changing flow or inlet pressure
- Two high flow 1/4" gauge ports can be used as additional outlets
- 1/2", 3/4" ports (NPT, BSPP)

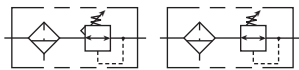

Port size	Description †	Part number
1/2"	Metal bowl, twist drain	<b>12E33E13AA</b>
1/2"	Metal bowl, auto float drain	<b>12E37E13AA</b>
3/4"	Metal bowl, twist drain	<b>12E43E13AA</b>
3/4"	Metal bowl, auto float drain	<b>12E47E13AA</b>

† For polycarbonate bowl, see caution in Engineering Section A.  
NOTE: 2.0 Dia. (50.8 mm) hole required for panel mounting. Max panel thickness 1/4"

**Operating information**

Supply pressure (max): Metal bowl	0 to 250 psig (0 to 17.2 bar)
Operating temperature: Metal bowl	32°F to 175°F (0°C to 80°C)
Secondary pressure range:	
Standard	2 to 125 psig (0 to 8.6 bar)
Low	1 to 60 psig (0 to 4.1 bar)
High	5 to 250 psig (0.4 to 17.2 bar)
Flow capacity†:	
High flow 1/2"	40 scfm (18.9 dm <sup>3</sup> /s, ANR)
3/4"	45 scfm (21.2 dm <sup>3</sup> /s, ANR)
Bowl capacity:	7.2 oz.
Gauge ports (2):	1/4 inch (can be used as additional full flow 1/4" outlet ports)
Sump capacity:	2.8 oz.
Weight:	2.5 lb (1.1 kg)

† scfm = Standard cubic feet per minute at 150 psig inlet, 90 psig no flow secondary setting and 10 psig pressure drop.

**Ordering information:**

<b>12E</b>	<b>3</b>	<b>2</b>	<b>E</b>	<b>13</b>	<b>A</b>	<b>A</b>			
<b>Port Size</b>						<b>Engineering Level</b>			<b>Preset / Pressure Limited</b>
1/2 inch	3					A Current			Blank None
3/4 inch	4								XXX* Preset pressure
									XXX* Pressure limited
						<b>Relief</b>			* Available preset range, 10 to 90 psig in 5 psig increments. For higher pressures, contact factory. (Example: 065 = 65 psig)
<b>Bowl Options</b>						A Relieving			
Metal bowl, twist drain	3					L Non-relieving			
Metal bowl, auto float drain	7								<b>Options</b>
			<b>Element</b>						Blank No options
			Grade 6 E						L † Preset non-adjustable
			Grade 10 H						p † Preset adjustable
									† Inlet Pressure is 100 psig. For other pressures, contact factory.
									<b>Port Type</b>
									Blank NPT
									1* BSPP
									* 1/2 inch meet ISO 1179-1 standard.

Spring Type by Preset / Limited Pressure:  
 For Preset / Limited Pressure 10 to 25 use 30 psi spring  
 For Preset / Limited Pressure 26 to 50 use 60 psi spring  
 For Preset / Limited Pressure 51 to 90 use 125 psi spring

\* If 250 psig spring range is used, use metal bowl.

□ Most popular.



## Coalescing Filter / Regulators

### Material Specifications

Adjusting stem	Steel
Body	Zinc
Bonnet, internal parts	Plastic
Metal bowl (without sight gauge)	Zinc
Collar for bonnet	Metal
Control spring	Steel
Diaphragm	Nitrile
Manual twist drain, standard, body & nut	Plastic
Auto float drain, housing, float	Plastic
Auto float drain, seals	Nitrile
Auto float drain, springs, push rod	Stainless steel
Knob	Plastic
Element	Borosilicate & felt glass fibers
Seals	Nitrile
Sight gauge	Polyamide
Poppet, spring	Stainless

### Repair and Service Kits

Bonnet assembly kit	PS715P
Metal bowl, auto float drain	PS826P
Metal bowl, twist drain	PS834P
Control knob	P04069B
Auto float drain	PS506P
Twist drain	PS512P
Grade 6 element (0.01 micron)	PS884P
Grade 10 element (1.0 micron)	PS885P
2" dial face 60 psig (0 to 4.1 bar), gauge	K4520N14060
2" dial face 160 psig (0 to 11.0 bar), gauge	K4520N14160
2" dial face 300 psig (0 to 20.7 bar), gauge	K4520N14300
1-3/4" digital round face 160 psig (0 to 11.0 bar), gauge	K4517N14160D
Mounting bracket kit (includes panel mount nut)	PS807P
Relieving (includes poppet)	PS886P
1- 30 psig spring	P01698
1- 60 psig spring	P04062
2- 125 psig spring	P04063
5- 250 psig spring	P04064
Tamperproof kit (key lock)	PS737P

## Air Preparation Products Prep-Air® II Series

### Flow Charts

#### 12E 1/2" Filter / Regulator

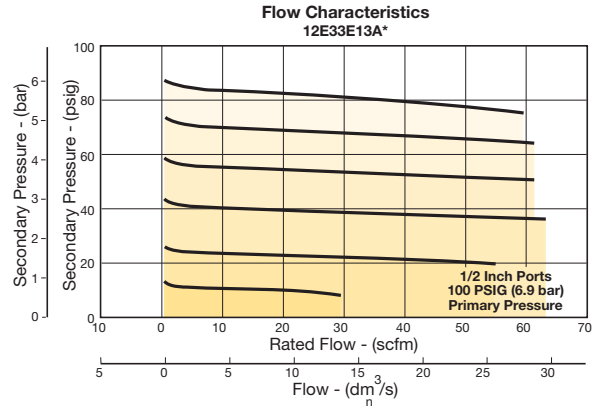

### WARNING

**Product rupture can cause serious injury.  
Do not connect regulator to bottled gas.  
Do not exceed Maximum primary pressure rating.**

### CAUTION:

**REGULATOR PRESSURE ADJUSTMENT** – The working range of knob adjustment is designed to permit outlet pressures within their full range. Pressure adjustment beyond this range is also possible because the knob is not a limiting device. This is a common characteristic of most industrial regulators, and limiting devices may be obtained only by special design. For best performance, regulated pressure should always be set by increasing the pressure up to the desired setting.

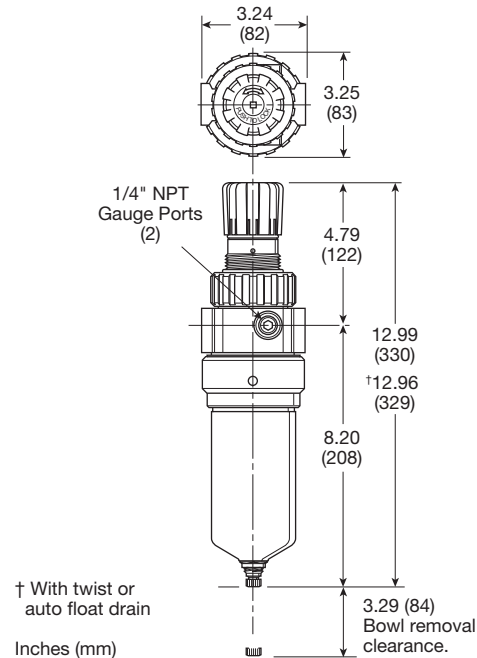

Prep-Air® II  
Products



Filters

Coalescers

Regulators

Filter /  
Regulators

Lubricators

Combinations

Accessories

**15L Micro-Mist Lubricators – Economy**

- Proportional oil delivery over a wide range of air flows
- Generates oil particles of 5 micron or smaller downstream to lubricate systems having complex piping arrangements
- Precision needle valve assures repeatable oil delivery and provides simple adjustment of delivery rate
- Ideal for low and high flow applications with changing air flow
- Transparent sight dome for 360° visibility
- Removable drip control knob for tamper resistance
- Integral 1/4" & 3/8" (NPT)



**Operating information**

Supply pressure (max):	Plastic bowl		150 psig (10.3 bar)
Operating temperature:	Plastic bowl		32°F to 125°F (0°C to 52°C)
Flow capacity†:	High flow	1/4"	40 scfm (18.9 dm³/s, ANR)
		3/8"	40 scfm (18.9 dm³/s, ANR)
Minimum flow			2 scfm (0.9 dm³/s, ANR) at 100 psig (6.9 bar)
Bowl capacity:			2.0 oz.
Weight			1.0 lb (0.45 kg)

† scfm = Standard cubic feet per minute at 90 psig inlet and 5 psig pressure drop.

Port size	Description ‡	Part number
1/4"	Poly bowl, metal guard, no drain	<b>15L12NA</b>
3/8"	Poly bowl, metal guard, no drain	<b>15L22NA</b>

‡ For polycarbonate bowl and sight dome, see caution in Engineering Section A.

**Ordering information:**

<b>15L</b>	<b>1</b>	<b>2</b>	<b>N</b>	<b>A</b>														
<table border="1"> <tr><th>Port Size</th><th></th></tr> <tr><td>1/4 inch</td><td>1</td></tr> <tr><td>3/8 inch</td><td>2</td></tr> </table>		Port Size		1/4 inch	1	3/8 inch	2	<table border="1"> <tr><th>Bowl Options</th><th></th></tr> <tr><td>Poly bowl with metal bowl guard, no drain</td><td>2</td></tr> </table>		Bowl Options		Poly bowl with metal bowl guard, no drain	2	<table border="1"> <tr><th>Engineering Level</th><th></th></tr> <tr><td>A</td><td>Current</td></tr> </table>	Engineering Level		A	Current
Port Size																		
1/4 inch	1																	
3/8 inch	2																	
Bowl Options																		
Poly bowl with metal bowl guard, no drain	2																	
Engineering Level																		
A	Current																	
			<table border="1"> <tr><th>Fill Options</th><th></th></tr> <tr><td>B</td><td>With fill plug</td></tr> <tr><td>N</td><td>No fill plug</td></tr> </table>		Fill Options		B	With fill plug	N	No fill plug								
Fill Options																		
B	With fill plug																	
N	No fill plug																	

**Suggested Lubricant** .....F442 Oil

Petroleum based oil of 100 to 200 SUS viscosity at 100°F (38°C) and an aniline point greater than 200°F (93°C)  
(DO NOT USE OILS WITH ADDITIVES, COMPOUNDED OILS CONTAINING SOLVENTS, GRAPHITE, DETERGENTS, OR SYNTHETIC OILS.)

Most popular.

Prep-Air® II Products  
  
 Filters  
 Coalescers  
 Regulators  
 Filter / Regulators  
 Lubricators  
 Combinations  
 Accessories



## Economy Micro-Mist Lubricators

### Material Specifications

Body	Zinc
Transparent bowl	Polycarbonate
Bowl guard	Steel
Collar	Plastic
Drains, twist – body & nut	Plastic
Injector meter block & base assembly	Plastic
Seals	Nitrile
Sight dome	Polycarbonate
Sight gauge	Polyamide (nylon)

### Repair and Service Kits

Adjustment knob	<b>P04121</b>
Bowl guard kit	<b>PS905P</b>
Poly bowl, no drain	<b>PS946P</b>
Twist drain	<b>PS512P</b>
Mounting bracket kit	<b>PS943P</b>
Service kit	<b>PS948P</b>
Sight dome kit	<b>PS740P</b>
Sight gauge kit	<b>PS914P</b>
Oil (1 quart)	<b>F442001</b>
Oil (1 gallon)	<b>F442002</b>
Oil (12 quart case)	<b>F442003</b>
Oil (4 gallon case)	<b>F442005</b>

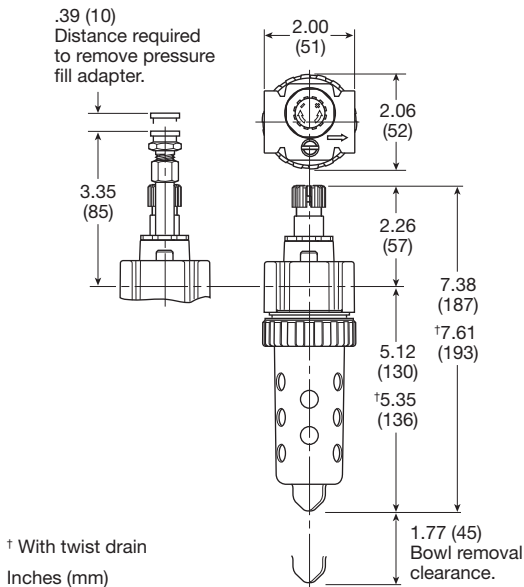

## Air Preparation Products Prep-Air® II Series

### Flow Charts

#### 15L 1/4" Lubricator

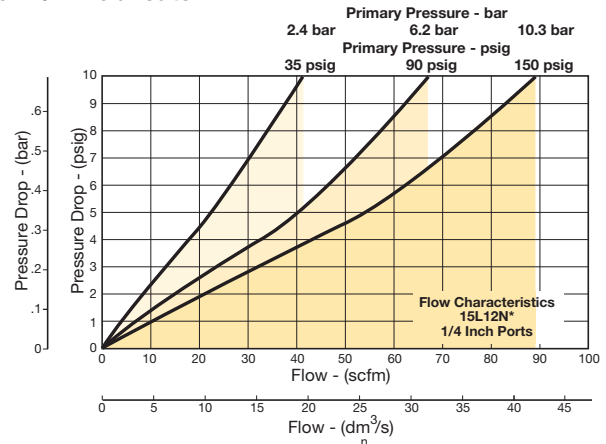

#### 15L 3/8" Lubricator

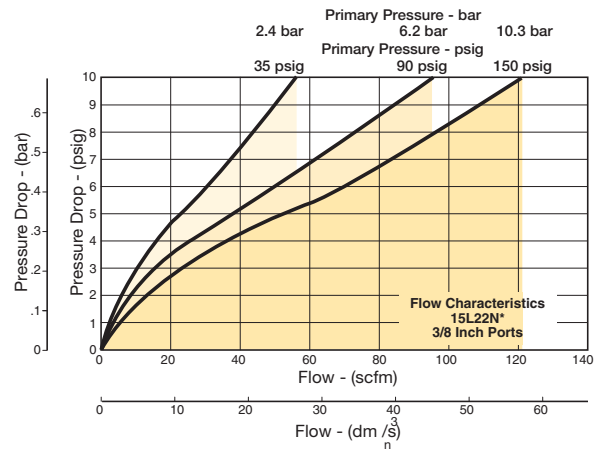

Prep-Air® II  
Products



Filters

Coalescers

Regulators

Filter /  
Regulators

Lubricators

Combinations

Accessories

**16L Micro-Mist Lubricators – Compact**

- Proportional oil delivery over a wide range of air flows
- Generates oil particles of 5 micron or smaller downstream to lubricate systems having complex piping arrangements
- Precision needle valve assures repeatable oil delivery and provides simple adjustment of delivery rate
- Ideal for low and high flow applications with changing air flow
- Transparent sight dome for 360° visibility
- Yellow fill cap identifies micro-mist lubricator
- Integral 1/4", 3/8", 1/2" (NPT, BSPP)



Port size	Description †	Part number
1/4"	Poly bowl, metal guard, no drain	<b>16L12BE</b>
1/4"	Metal bowl, sight gauge, twist drain	<b>16L14BE</b>
3/8"	Poly bowl, metal guard, no drain	<b>16L22BE</b>
3/8"	Metal bowl, sight gauge, twist drain	<b>16L24BE</b>
1/2"	Poly bowl, metal guard, no drain	<b>16L32BE</b>
1/2"	Metal bowl, sight gauge, twist drain	<b>16L34BE</b>

† For polycarbonate bowl and sight dome, see caution in Engineering Section A.

**Operating information**

Supply pressure (max):		
Plastic bowl		150 psig (10.3 bar)
Metal bowl		250 psig (17.2 bar)
Operating temperature:		
Plastic bowl		32°F to 125°F (0°C to 52°C)
Metal bowl		32°F to 175°F (0°C to 80°C)
Flow capacity†:		
High flow	1/4"	40 scfm (18.9 dm³/s, ANR)
	3/8"	60 scfm (28.3 dm³/s, ANR)
	1/2"	90 scfm (42.5 dm³/s, ANR)
Minimum flow		1 scfm (0.5 dm³/s, ANR) at 100 psig (6.9 bar)
Bowl capacity:		2.6 oz.
Weight:		1.2 lb (0.5 kg)

† scfm = Standard cubic feet per minute at 90 psig inlet and 5 psig pressure drop.

**Ordering information:**

16L
1
2
B
E

Port Size	Port Type
1/4 inch	Blank NPT
3/8 inch	1* BSPP
1/2 inch	

\* 1/4 & 3/8 inch meet ISO 1179-1 Standard.

Bowl Options	Engineering Level	Fill Options
Poly bowl, metal bowl guard, no drain	E	B With fill plug
Poly bowl, metal bowl guard, pressure fill		C With fill plug / nylon sight dome
Poly bowl, metal bowl guard, auto fill device		F With body pressure fill
Poly bowl, metal bowl guard, twist drain		G With body pressure fill / nylon sight dome
Metal bowl, sight gauge, twist drain		
Metal bowl, sight gauge, pressure fill		
Metal bowl, sight gauge, auto fill device		

**Suggested Lubricant** ..... **F442 Oil**

Petroleum based oil of 100 to 200 SUS viscosity at 100°F (38°C) and an aniline point greater than 200°F (93°C)

(DO NOT USE OILS WITH ADDITIVES, COMPOUNDED OILS CONTAINING SOLVENTS, GRAPHITE, DETERGENTS, OR SYNTHETIC OILS.)

  Most popular.

Prep-Air® II Products  
 Filters  
 Coalescers  
 Regulators  
 Filter / Regulators  
 Lubricators  
 Combinations  
 Accessories



## Compact Micro-Mist Lubricators

### Material Specifications

Body	Zinc
Transparent bowls	Polycarbonate
Metal bowl (with sight gauge)	Zinc
Bowl guard	Steel
Collar	Plastic
Twist drain – body & nut	Plastic
Injector meter block & base assembly	Plastic
Seals	Nitrile
Sight dome	Polycarbonate
Sight gauge	Polyamide (nylon)

### Repair and Service Kits

Adjustment knob	<b>P04121</b>
Bowl guard kit	<b>PS705P</b>
Poly bowl / no drain kit	<b>PS746P</b>
Poly bowl / twist drain kit	<b>PS717P</b>
Poly bowl / pressure fill kit	<b>PS719P</b>
Poly bowl / remote fill kit	<b>PS728P</b>
Metal bowl / sight gauge / twist drain kit	<b>PS729P</b>
Metal bowl / sight gauge / pressure fill kit	<b>PS720P</b>
Twist drain kit	<b>PS512P</b>
Fill cap kit	<b>PS742P</b>
Lubricator service kit	<b>PS748P</b>
Mounting bracket kit	<b>PS743P</b>
Pressure fill adapter kit	<b>PS716P</b>
Pressure fill button	<b>P11912</b>
Remote auto-fill device	<b>PS505CP</b>
Sight dome / fill cap kit	<b>PS739P</b>
Sight dome kit, polycarbonate	<b>PS740P</b>
Sight dome kit, nylon	<b>PS740N</b>
Oil (1 quart)	<b>F442001</b>
Oil (1 gallon)	<b>F442002</b>
Oil (12 quart case)	<b>F442003</b>
Oil (4 gallon case)	<b>F442005</b>

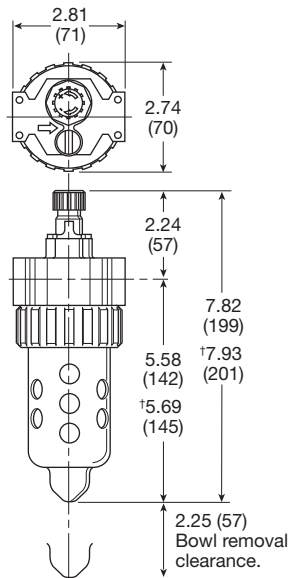

† With twist drain  
Inches (mm)

## Air Preparation Products Prep-Air® II Series

### Flow Charts

#### 16L 1/4" Lubricator

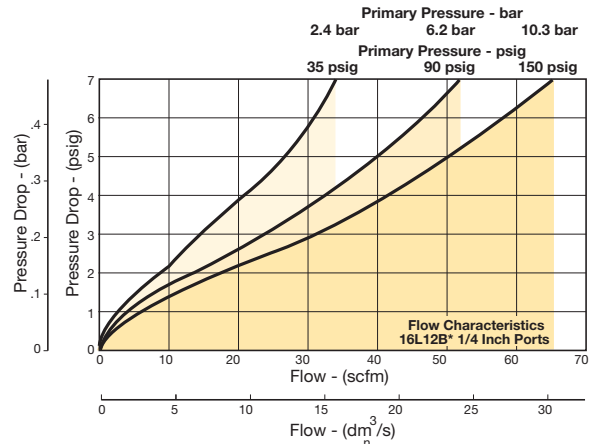

#### 16L 3/8" Lubricator

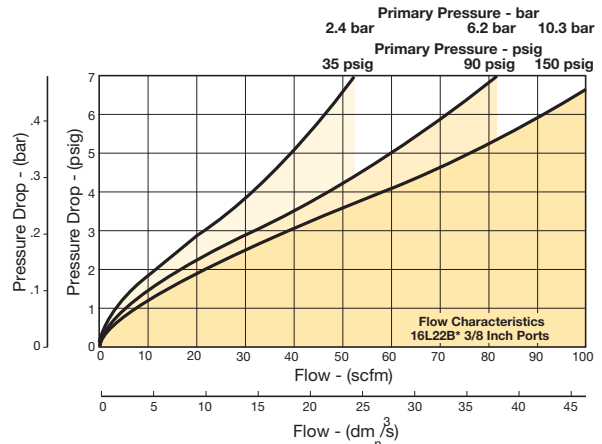

#### 16L 1/2" Lubricator

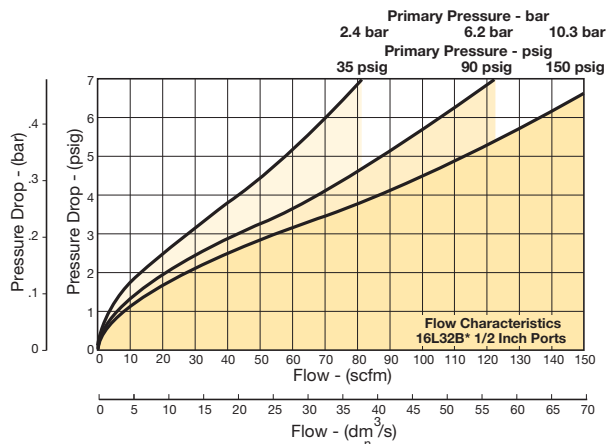

Prep-Air® II  
Products



Filters

Coalescers

Regulators

Filter/  
Regulators

Lubricators

Combinations

Accessories



**17L Micro-Mist Lubricators – Standard**

- Proportional oil delivery over a wide range of air flows
- Generates oil particles of 5 micron or smaller downstream to lubricate systems having complex piping arrangements
- Precision needle valve assures repeatable oil delivery and provides simple adjustment of delivery rate
- Ideal for low and high flow applications with changing air flow
- Transparent sight dome for 360° visibility
- Yellow fill cap identifies Micro-Mist Lubricator.
- Integral 1/2", 3/4" ports (NPT, BSPP)



Port size	Description ‡	Part number
1/2"	Poly bowl, metal guard, no drain	<b>17L32BE</b>
1/2"	Metal bowl, sight gauge, twist drain	<b>17L34BE</b>
3/4"	Poly bowl, metal guard, no drain	<b>17L42BE</b>
3/4"	Metal bowl, sight gauge, twist drain	<b>17L44BE</b>

‡ For polycarbonate bowl and sight dome, see caution in Engineering Section A.

**Operating information**

Supply pressure (max):		
Plastic bowl		150 psig (10.3 bar)
Metal bowl		250 psig (17.2 bar)
Operating temperature:		
Plastic bowl		32°F to 125°F (0°C to 52°C)
Metal bowl		32°F to 175°F (0°C to 80°C)
Flow capacity†:		
High flow	1/2"	90 scfm (42.5 dm³/s, ANR)
	3/4"	90 scfm (42.5 dm³/s, ANR)
Minimum flow		1 scfm (0.5 dm³/s, ANR) at 100 psig (6.9 bar)
Bowl capacity:		4.9 oz.
Weight:		1.9 lb (0.9 kg)

† scfm = Standard cubic feet per minute at 90 psig inlet and 5 psig pressure drop.

**Ordering information:**

<b>17L</b>	<b>3</b>	<b>2</b>	<b>B</b>	<b>E</b>	
<b>Port Size</b>					<b>Port Type</b>
1/2 inch	3				Blank NPT
3/4 inch	4				1* BSPP
					* 1/2 inch meet ISO 1179-1 Standard.
<b>Bowl Options</b>				<b>Engineering Level</b>	
Poly bowl, metal bowl guard, no drain	2			E	Current
Poly bowl, metal bowl guard, pressure fill	6				
Poly bowl, metal bowl guard, auto fill device	K				
Poly bowl, metal bowl guard, twist drain	N				
Metal bowl, sight gauge, twist drain	4				
Metal bowl, sight gauge, pressure fill	8				
Metal bowl, sight gauge, auto fill device	M				
				<b>Fill Options</b>	
			B		With fill plug
			C		With fill plug / nylon sight dome
			F		With body pressure fill
			G		With body pressure fill / nylon sight dome

**Suggested Lubricant** .....F442 Oil

Petroleum based oil of 100 to 200 SUS viscosity at 100°F (38°C) and an aniline point greater than 200°F (93°C)  
(DO NOT USE OILS WITH ADDITIVES, COMPOUNDED OILS CONTAINING SOLVENTS, GRAPHITE, DETERGENTS, OR SYNTHETIC OILS.)

Most popular.

Prep-Air® II Products  
 Filters  
 Coalescers  
 Regulators  
 Filter / Regulators  
 Lubricators  
 Combinations  
 Accessories





## Standard Micro-Mist Lubricators

### Material Specifications

Body	Zinc
Transparent bowl	Polycarbonate
Metal bowl (with sight gauge)	Zinc
Bowl guard	Steel
Collar	Plastic or Metal
Twist drain- body & nut	Plastic
Injector meter block & base assembly	Plastic
Seals	Nitrile
Sight dome	Polycarbonate
Sight gauge	Polyamide (nylon)

## Air Preparation Products

### Prep-Air® II Series

### Flow Charts

#### 17L 1/2" & 3/4" Lubricator

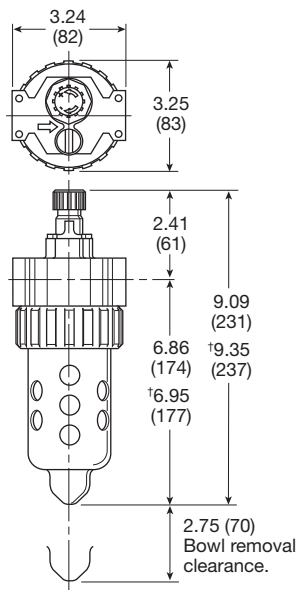
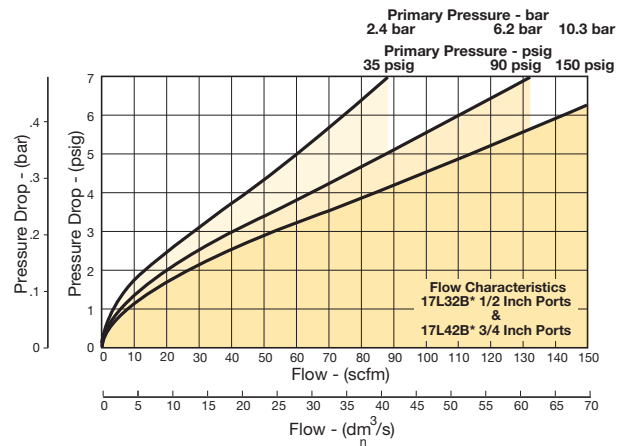

† With twist drain  
Inches (mm)

### Repair and Service Kits

Adjustment knob	<b>P04121</b>
Bowl guard kit	<b>PS805P</b>
Poly bowl / no drain kit	<b>PS846P</b>
Poly bowl / twist drain kit	<b>PS817P</b>
Poly bowl / pressure fill kit	<b>PS819P</b>
Poly bowl / remote fill kit	<b>PS828P</b>
Metal bowl / sight gauge / twist drain kit	<b>PS829P</b>
Metal bowl / sight gauge / pressure fill kit	<b>PS820P</b>
Twist drain kit	<b>PS512P</b>
Fill cap kit	<b>PS742P</b>
Lubricator service kit	<b>PS748P</b>
Mounting bracket kit	<b>PS843P</b>
Pressure fill adapter kit	<b>PS716P</b>
Pressure fill button	<b>P11912</b>
Remote auto-fill device	<b>PS505CP</b>
Sight dome / fill cap kit	<b>PS739P</b>
Sight dome kit, polycarbonate	<b>PS740P</b>
Sight dome kit, nylon	<b>PS740N</b>
Oil (1 quart)	<b>F442001</b>
Oil (1 gallon)	<b>F442002</b>
Oil (12 quart case)	<b>F442003</b>
Oil (4 gallon case)	<b>F442005</b>

Prep-Air® II  
Products



Filters

Coalescers

Regulators

Filter /  
Regulators

Lubricators

Combinations

Accessories

**06L Mist Lubricators – Compact**

- Proportional oil delivery over a wide range of air flows.
- Precision needle valve assures repeatable oil delivery and provides simple adjustment of delivery rate.
- Bowl can be filled while air line is under pressure.
- Transparent sight dome for 360° visibility.
- Integral 1/4", 3/8", 1/2" ports (NPT, BSPP)



Port size	Description †	Part number
1/4"	Poly bowl, metal guard, no drain	<b>06L12BE</b>
1/4"	Metal bowl, sight gauge, twist drain	<b>06L14BE</b>
3/8"	Poly bowl, metal guard, no drain	<b>06L22BE</b>
3/8"	Metal bowl, sight gauge, twist drain	<b>06L24BE</b>
1/2"	Poly bowl, metal guard, no drain	<b>06L32BE</b>
1/2"	Metal bowl, sight gauge, twist drain	<b>06L34BE</b>

† For polycarbonate bowl and sight dome, see caution in Engineering Section A.

**Operating information**

Supply pressure (max):		
Plastic bowl		150 psig (10.3 bar)
Metal bowl		250 psig (17.2 bar)
Operating temperature:		
Plastic bowl		32°F to 125°F (0°C to 52°C)
Metal bowl		32°F to 175°F (0°C to 80°C)
Flow capacity†:		
High flow	1/4"	40 scfm (18.9 dm³/s, ANR)
	3/8"	60 scfm (28.3 dm³/s, ANR)
	1/2"	90 scfm (42.5 dm³/s, ANR)
Minimum flow		0.5 2 scfm (0.24 dm³/s, ANR) at 100 psig (6.9 bar)
Bowl capacity:		2.9 oz.
Weight:		1.2 lb (0.5 kg)

† scfm = Standard cubic feet per minute at 90 psig inlet and 5 psig pressure drop.

**Ordering information:**

<b>06L</b>	<b>1</b>	<b>2</b>	<b>B</b>	<b>E</b>	<b>Blank</b>													
<table border="1"> <thead> <tr><th>Port Size</th></tr> </thead> <tbody> <tr><td>1/4 inch</td></tr> <tr><td>3/8 inch</td></tr> <tr><td>1/2 inch</td></tr> </tbody> </table>		Port Size	1/4 inch	3/8 inch	1/2 inch	<table border="1"> <thead> <tr><th>Port Type</th></tr> </thead> <tbody> <tr><td>Blank</td></tr> <tr><td>1*</td></tr> </tbody> </table> <p>* 1/4 &amp; 3/8 inch meet ISO 1179-1 Standard.</p>		Port Type	Blank	1*	<table border="1"> <thead> <tr><th>Engineering Level</th></tr> </thead> <tbody> <tr><td>E</td></tr> </tbody> </table>		Engineering Level	E				
Port Size																		
1/4 inch																		
3/8 inch																		
1/2 inch																		
Port Type																		
Blank																		
1*																		
Engineering Level																		
E																		
<table border="1"> <thead> <tr><th>Bowl Options</th></tr> </thead> <tbody> <tr><td>Poly bowl, metal bowl guard, no drain</td></tr> <tr><td>Poly bowl, metal bowl guard, pressure fill</td></tr> <tr><td>Poly bowl, metal bowl guard, auto fill device</td></tr> <tr><td>Poly bowl, metal bowl guard, twist drain</td></tr> <tr><td>Metal bowl, sight gauge, twist drain</td></tr> <tr><td>Metal bowl, sight gauge, pressure fill</td></tr> <tr><td>Metal bowl, sight gauge, auto fill device</td></tr> </tbody> </table>			Bowl Options	Poly bowl, metal bowl guard, no drain	Poly bowl, metal bowl guard, pressure fill	Poly bowl, metal bowl guard, auto fill device	Poly bowl, metal bowl guard, twist drain	Metal bowl, sight gauge, twist drain	Metal bowl, sight gauge, pressure fill	Metal bowl, sight gauge, auto fill device	<table border="1"> <thead> <tr><th>Fill Options</th></tr> </thead> <tbody> <tr><td>B</td></tr> <tr><td>C</td></tr> <tr><td>F</td></tr> <tr><td>G</td></tr> </tbody> </table>			Fill Options	B	C	F	G
Bowl Options																		
Poly bowl, metal bowl guard, no drain																		
Poly bowl, metal bowl guard, pressure fill																		
Poly bowl, metal bowl guard, auto fill device																		
Poly bowl, metal bowl guard, twist drain																		
Metal bowl, sight gauge, twist drain																		
Metal bowl, sight gauge, pressure fill																		
Metal bowl, sight gauge, auto fill device																		
Fill Options																		
B																		
C																		
F																		
G																		

**Suggested Lubricant** .....F442 Oil  
 Petroleum based oil of 100 to 200 SUS viscosity at 100°F (38°C) and an aniline point greater than 200°F (93°C)  
 (DO NOT USE OILS WITH ADDITIVES, COMPOUNDED OILS CONTAINING SOLVENTS, GRAPHITE, DETERGENTS, OR SYNTHETIC OILS.)

Most popular.

Prep-Air® II Products  
 Filters  
 Coalescers  
 Regulators  
 Filter / Regulators  
 Lubricators  
 Combinations  
 Accessories



## Compact Mist Lubricators

### Material Specifications

Body	Zinc
Transparent bowl	Polycarbonate
Metal bowl (with sight gauge)	Zinc
Bowl guard	Steel
Collar	Plastic
Twist drain – body & nut	Plastic
Injector meter block & base assembly	Plastic
Seals	Nitrile
Sight dome	Polycarbonate
Sight gauge	Polyamide (nylon)

### Repair and Service Kits

Adjustment knob	<b>P04121</b>
Bowl guard kit	<b>PS705P</b>
Poly bowl / no drain kit	<b>PS746P</b>
Poly bowl / twist drain kit	<b>PS717P</b>
Poly bowl / pressure fill kit	<b>PS719P</b>
Poly bowl / remote fill kit	<b>PS728P</b>
Metal bowl / sight gauge / twist drain kit	<b>PS729P</b>
Metal bowl / sight gauge / pressure fill kit	<b>PS720P</b>
Twist drain kit	<b>PS512P</b>
Fill cap kit	<b>PS741P</b>
Lubricator service kit	<b>PS718P</b>
Mounting bracket kit	<b>PS743P</b>
Pressure fill adapter kit	<b>PS716P</b>
Pressure fill button	<b>P11912</b>
Remote auto-fill device	<b>PS505CP</b>
Sight dome / fill cap kit	<b>PS738P</b>
Sight dome kit, polycarbonate	<b>PS740P</b>
Sight dome kit, nylon	<b>PS740N</b>
Oil (1 quart)	<b>F442001</b>
Oil (1 gallon)	<b>F442002</b>
Oil (12 quart case)	<b>F442003</b>
Oil (4 gallon case)	<b>F442005</b>

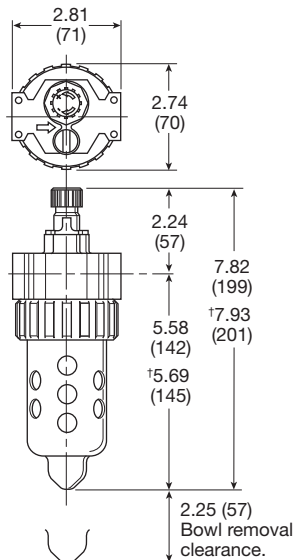

† With twist drain  
Inches (mm)

## Air Preparation Products Prep-Air® II Series

### Flow Charts

#### 06L 1/4" Lubricator

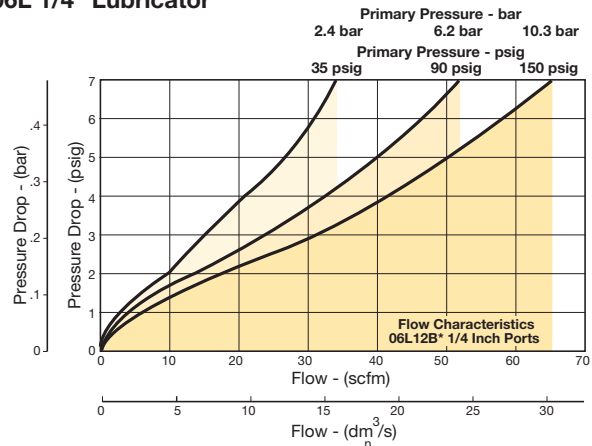

#### 06L 3/8" Lubricator

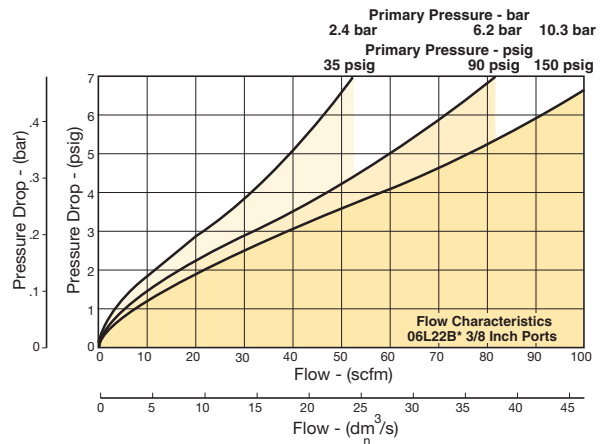

#### 06L 1/2" Lubricator

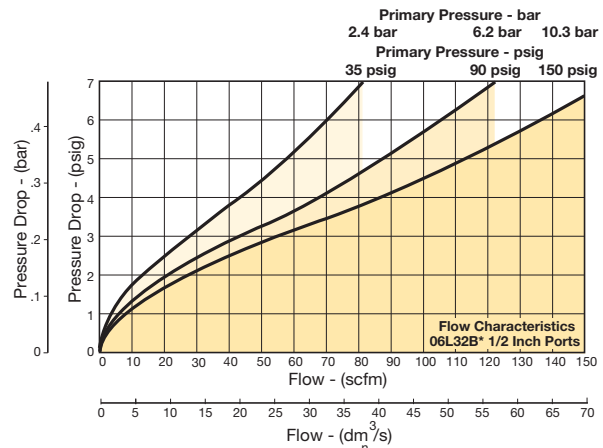

Prep-Air® II  
Products



Filters

Coalescers

Regulators

Filter /  
Regulators

Lubricators

Combinations

Accessories

**07L Mist Lubricators – Standard**

- Proportional oil delivery over a wide range of air flows
- Precision needle valve assures repeatable oil delivery and provides simple adjustment of delivery rate
- Bowl can be filled while air line is under pressure
- Transparent sight dome for 360° visibility
- Integral 1/2", 3/4" ports (NPT, BSPP)



Port size	Description †	Part number
1/2"	Poly bowl, metal guard, no drain	<b>07L32BE</b>
1/2"	Metal bowl, sight gauge, twist drain	<b>07L34BE</b>
3/4"	Poly bowl, metal guard, no drain	<b>07L42BE</b>
3/4"	Metal bowl, sight gauge, twist drain	<b>07L44BE</b>

† For polycarbonate bowl and sight dome, see caution in Engineering Section A.

**Operating information**

Supply pressure (max):		
Plastic bowl		150 psig (10.3 bar)
Metal bowl		250 psig (17.2 bar)
Operating temperature:		
Plastic bowl		32°F to 125°F (0°C to 52°C)
Metal bowl		32°F to 175°F (0°C to 80°C)
Flow capacity†:		
High flow	1/2"	90 scfm (42.5 dm <sup>3</sup> /s, ANR)
	3/4"	90 scfm (42.5 dm <sup>3</sup> /s, ANR)
Minimum flow		0.5 2 scfm (0.24 dm <sup>3</sup> /s, ANR) at 100 psig (6.9 bar)
Bowl capacity:		6.0 oz.
Weight:		1.9 lb (0.9 kg)

† scfm = Standard cubic feet per minute at 90 psig inlet and 5 psig pressure drop.

**Ordering information:**

<b>07L</b>	<b>3</b>	<b>2</b>	<b>B</b>	<b>E</b>	<b>Blank</b>										
<table border="1"> <thead> <tr><th>Port Size</th></tr> </thead> <tbody> <tr><td>1/2 inch</td></tr> <tr><td>3/4 inch</td></tr> </tbody> </table>		Port Size	1/2 inch	3/4 inch				<table border="1"> <thead> <tr><th>Port Type</th></tr> </thead> <tbody> <tr><td>Blank</td></tr> <tr><td>1*</td></tr> </tbody> </table> <p>* 1/2 inch meet ISO 1179-1 Standard.</p>	Port Type	Blank	1*				
Port Size															
1/2 inch															
3/4 inch															
Port Type															
Blank															
1*															
<table border="1"> <thead> <tr><th>Bowl Options</th></tr> </thead> <tbody> <tr><td>Poly bowl, metal bowl guard, no drain</td></tr> <tr><td>Poly bowl, metal bowl guard, pressure fill</td></tr> <tr><td>Poly bowl, metal bowl guard, auto fill device</td></tr> <tr><td>Poly bowl, metal bowl guard, twist drain</td></tr> <tr><td>Metal bowl, sight gauge, twist drain</td></tr> <tr><td>Metal bowl, sight gauge, pressure fill</td></tr> <tr><td>Metal bowl, sight gauge, auto fill device</td></tr> </tbody> </table>		Bowl Options	Poly bowl, metal bowl guard, no drain	Poly bowl, metal bowl guard, pressure fill	Poly bowl, metal bowl guard, auto fill device	Poly bowl, metal bowl guard, twist drain	Metal bowl, sight gauge, twist drain	Metal bowl, sight gauge, pressure fill	Metal bowl, sight gauge, auto fill device			<table border="1"> <thead> <tr><th>Engineering Level</th></tr> </thead> <tbody> <tr><td>E</td></tr> </tbody> </table>	Engineering Level	E	
Bowl Options															
Poly bowl, metal bowl guard, no drain															
Poly bowl, metal bowl guard, pressure fill															
Poly bowl, metal bowl guard, auto fill device															
Poly bowl, metal bowl guard, twist drain															
Metal bowl, sight gauge, twist drain															
Metal bowl, sight gauge, pressure fill															
Metal bowl, sight gauge, auto fill device															
Engineering Level															
E															
			<table border="1"> <thead> <tr><th>Fill Options</th></tr> </thead> <tbody> <tr><td>B</td></tr> <tr><td>C</td></tr> <tr><td>F</td></tr> <tr><td>G</td></tr> </tbody> </table>			Fill Options	B	C	F	G					
Fill Options															
B															
C															
F															
G															

**Suggested Lubricant** .....F442 Oil  
 Petroleum based oil of 100 to 200 SUS viscosity at 100°F (38°C) and an aniline point greater than 200°F (93°C)  
 (DO NOT USE OILS WITH ADDITIVES, COMPOUNDED OILS CONTAINING SOLVENTS, GRAPHITE, DETERGENTS, OR SYNTHETIC OILS.)

Most popular.

Prep-Air® II Products  
 Filters  
 Coalescers  
 Regulators  
 Filter / Regulators  
 Lubricators  
 Combinations  
 Accessories



## Standard Mist Lubricators

### Material Specifications

Body	Zinc
Transparent bowl	Polycarbonate
Metal bowl (with sight gauge)	Zinc
Bowl guard	Steel
Collar	Plastic or metal
Twist drain – body & nut	Plastic
Injector meter block & base assembly	Plastic
Seals	Nitrile
Sight dome	Polycarbonate
Sight gauge	Polyamide (nylon)

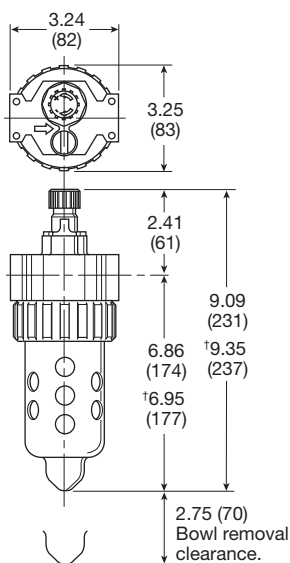

† With twist drain  
Inches (mm)

## Air Preparation Products Prep-Air® II Series

### Flow Charts

#### 07L 1/2" & 3/4" Lubricator

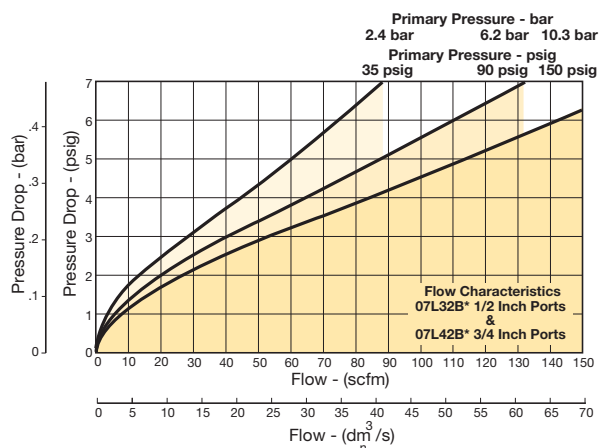

### Repair and Service Kits

Adjustment knob	P04121
Bowl guard kit	PS805P
Poly bowl / no drain	PS846P
Poly bowl / twist drain	PS817P
Poly bowl / pressure fill	PS819P
Poly bowl / remote fill	PS828P
Metal bowl / sight gauge / twist drain	PS829P
Metal bowl / sight gauge / pressure fill	PS820P
Twist drain kit	PS512P
Fill cap kit	PS741P
Lubricator service kit	PS718P
Mounting bracket kit	PS843P
Pressure fill adapter kit	PS716P
Pressure fill button	P11912
Remote auto-fill device	PS505CP
Sight dome / fill cap kit	PS738P
Sight dome kit, polycarbonate	PS740P
Sight dome kit, nylon	PS740N
Oil (1 quart)	F442001
Oil (1 gallon)	F442002
Oil (12 quart case)	F442003
Oil (4 gallon case)	F442005

Prep-Air® II  
Products



Filters

Coalescers

Regulators

Filter /  
Regulators

Lubricators

Combinations

Accessories

06 Compact, 07 Standard Close Nippled Series Combinations

- Regulator can be mounted with knob in up or down position
- 40 micron filter element standard, 5 micron optional
- Manual twist drain
- Relieving regulator

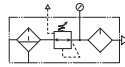
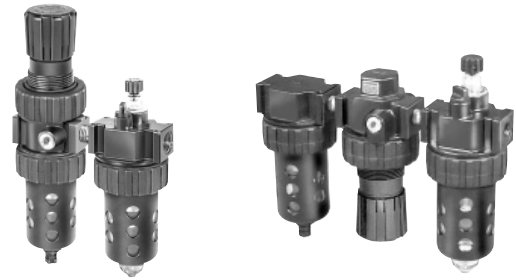

Close Nippled Combinations

Port	Bowl type ‡	Element type	Filter drain type	Relief type	Lubricator drain type	Series	Part numbers	Series†	Part numbers
							06G		16G
1/4"	Poly / Metal guard	40 micron	Twist	Relieving	None		06G12A13A2BC		16G12A13A2BC
3/8"	Poly / Metal guard	40 micron	Twist	Relieving	None	06G	06G22A13A2BC	16G	16G22A13A2BC
1/2"	Poly / Metal guard	40 micron	Twist	Relieving	None		06G32A13A2BC		16G32A13A2BC
1/2"	Poly / Metal guard	40 micron	Twist	Relieving	None	07G	07G32A13A2BD	17G	17G32A13A2BD
3/4"	Poly / Metal guard	40 micron	Twist	Relieving	None		07G42A13A2BD		17G42A13A2BD

Port	Bowl type ‡	Element type	Filter drain type	Relief type	Lubricator drain type	Series	Model numbers	Series†	Model numbers
							06A		16A
1/4"	Poly / Metal guard	40 micron	Twist	Relieving	None		06A12A13A2BC		16A12A13A2BC
3/8"	Poly / Metal guard	40 micron	Twist	Relieving	None	06A	06A22A13A2BC	16A	16A22A13A2BC
1/2"	Poly / Metal guard	40 micron	Twist	Relieving	None		06A32A13A2BC		16A32A13A2BC
1/2"	Poly / Metal guard	40 micron	Twist	Relieving	None	07A	07A32A13A2BD	17A	17A32A13A2BD
3/4"	Poly / Metal guard	40 micron	Twist	Relieving	None		07A42A13A2BD		17A42A13A2BD

\* 06 / 16 Available with port blocks only  
 ‡ For polycarbonate bowl, see caution in Engineering Section A  
 † 16G / 16A and 17G / 17A are Micro Mist version lubricators

**WARNING**

Product rupture can cause serious injury.  
 Do not connect regulator to bottled gas.  
 Do not exceed Maximum primary pressure rating.

**CAUTION:**

**REGULATOR PRESSURE ADJUSTMENT** – The working range of knob adjustment is designed to permit outlet pressures within their full range. Pressure adjustment beyond this range is also possible because the knob is not a limiting device. This is a common characteristic of most industrial regulators, and limiting devices may be obtained only by special design. For best performance, regulated pressure should always be set by increasing the pressure up to the desired setting.

Most popular.

Prep-Air® II Products

Filters

Coalescers

Regulators

Filter / Regulators

Lubricators

Combinations

Accessories



Ordering information:

<b>Series</b>		<b>Port Size</b>		<b>Filter Bowl Options</b>		<b>Filter Element</b>		<b>Engineering Level</b>		<b>Lubricator Body Options</b>		<b>Lubricator Bowl Options</b>		<b>Relief</b>		<b>Pressure Range</b>		
Micro-mist compact, 3-unit	16A	1/4 inch	1	Poly bowl, metal bowl guard, twist drain	2	40 Micron	A	C	06A, 16A, 06G, 16G	B	2	Poly bowl, metal bowl guard, no drain	A	Without gauge	11	60 psig	16	60 psig
Micro-mist standard, 3-unit	17A	3/8 inch (06/16)	2	Poly bowl, metal bowl guard, auto float drain	6	5 Micron	B	D	07A, 17A, 07G, 17G	F	6	Poly bowl, bowl guard, pressure fill	L	With gauge	13	125 psig	18	125 psig
Micro-mist compact, 2-unit	16G	1/2 inch	3	Metal bowl, twist drain	3						4	Metal bowl, sight gauge, twist drain			15*	250 psig	21*	250 psig
Micro-mist standard, 2-unit	17G	3/4 inch (07/17)	4	Metal bowl, sight gauge, auto float drain	4						8	Metal bowl, sight gauge, pressure fill						
Mist compact, 3-unit	06A			Metal bowl, auto float drain	7						M	Metal bowl, sight gauge, auto fill						
Mist standard, 3-unit	07A			Metal bowl, sight gauge, auto float drain	8													
Mist compact, 2-unit	06G																	
Mist standard, 2-unit	07G																	

\* Only available on metal bowl.

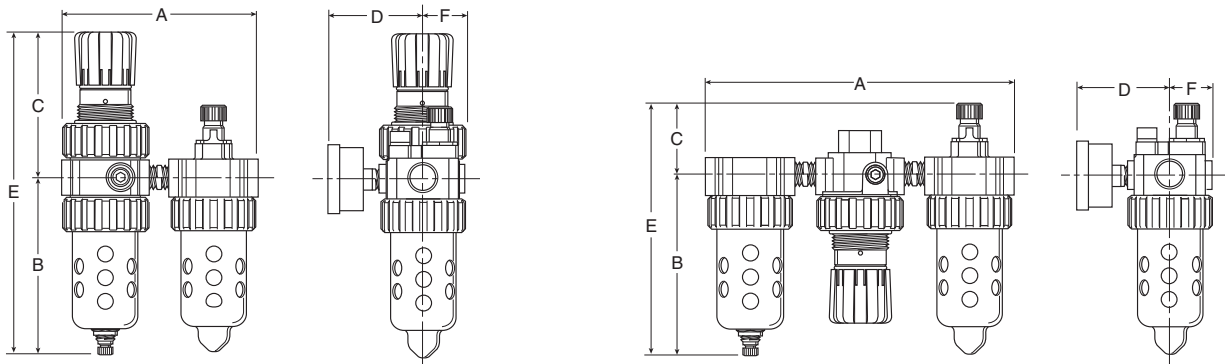

06G, 16G Series

A	B	C	D	E	F
6.13 (156)	5.69 (145)	4.69 (119)	3.18 (81)	10.38 (264)	1.37 (35)

07G, 17G Series

A	B	C	D	E	F
6.99 (178)	6.97 (177)	4.79 (122)	3.44 (87)	11.76 (299)	1.63 (41)

Inches (mm)

• All dimensions nominal.

06A, 16A Series

A	B	C	D	E	F
9.45 (240)	5.69 (145)	2.24 (57)	3.18 (81)	7.93 (201)	1.37 (35)

07A, 17A Series

A	B	C	D	E	F
10.74 (2738)	6.97 (177)	2.41 (61)	3.44 (87)	9.38 (238)	1.63 (41)

Inches (mm)

• All dimensions nominal.

Prep-Air® II  
Products



Filters

Coalescers

Regulators

Filter /  
Regulators

Lubricators

Combinations

Accessories





**06 Compact, 07 Standard Modular Series Combinations**

- Regulator can be mounted with knob in up or down position
- 40 micron filter element standard, 5 micron optional
- Manual twist drain
- Relieving regulator

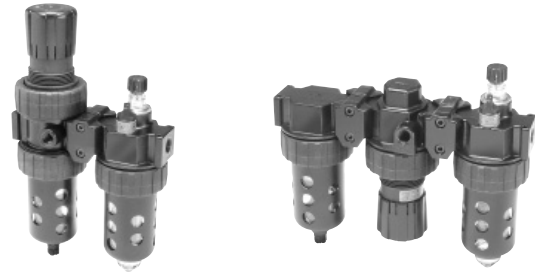

**Modular Combinations**

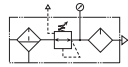

Prep-Air® II  
Products



Filters



06H Shown

Port	Bowl type ‡	Element type	Filter drain type	Relief type	Lubricator drain type	Series	Part numbers	Series †	Part numbers
1/4"	Poly / metal guard	40 micron	Twist	Relieving	None	06H	<b>06H12A13A2BC</b>	16H	<b>16H12A13A2BC</b>
3/8"	Poly / metal guard	40 micron	Twist	Relieving	None		<b>06H22A13A2BC</b>		<b>16H22A13A2BC</b>
1/2" *	Poly / metal guard	40 micron	Twist	Relieving	None		<b>06H32A13A2BCG</b>		<b>16H32A13A2BCG</b>
1/2"	Poly / metal guard	40 micron	Twist	Relieving	None	07H	<b>07H32A13A2BD</b>	17H	<b>17H32A13A2BD</b>
3/4"	Poly / metal guard	40 micron	Twist	Relieving	None		<b>07H42A13A2BD</b>		<b>17H42A13A2BD</b>

Coalescers



06B Shown

Port	Bowl type ‡	Element type	Filter drain type	Relief type	Lubricator drain type	Series	Model numbers	Series †	Model numbers
1/4"	Poly / metal guard	40 micron	Twist	Relieving	None	06B	<b>06B12A13A2BC</b>	16B	<b>16B12A13A2BC</b>
3/8"	Poly / metal guard	40 micron	Twist	Relieving	None		<b>06B22A13A2BC</b>		<b>16B22A13A2BC</b>
1/2" *	Poly / metal guard	40 micron	Twist	Relieving	None		<b>06B32A13A2BCG</b>		<b>16B32A13A2BCG</b>
1/2"	Poly / metal guard	40 micron	Twist	Relieving	None	07B	<b>07B32A13A2BD</b>	17B	<b>17B32A13A2BD</b>
3/4"	Poly / metal guard	40 micron	Twist	Relieving	None		<b>07B42A13A2BD</b>		<b>17B42A13A2BD</b>

\* 06 / 16 Available with port blocks only  
 ‡ For polycarbonate bowl, see caution in Engineering Section A  
 † 16H / 16B and 17H / 17B are Micro Mist version lubricators

Filter /  
Regulators

**⚠ WARNING**

**Product rupture can cause serious injury.  
Do not connect regulator to bottled gas.  
Do not exceed Maximum primary pressure rating.**

Lubricators

**CAUTION:**

**REGULATOR PRESSURE ADJUSTMENT** – The working range of knob adjustment is designed to permit outlet pressures within their full range. Pressure adjustment beyond this range is also possible because the knob is not a limiting device. This is a common characteristic of most industrial regulators, and limiting devices may be obtained only by special design. For best performance, regulated pressure should always be set by increasing the pressure up to the desired setting.

Combinations

Most popular.

Accessories



Ordering information:

<b>16B</b>	<b>1</b>	<b>2</b>	<b>A</b>	<b>13</b>	<b>A</b>	<b>2</b>	<b>B</b>	<b>C</b>	<b></b>
------------	----------	----------	----------	-----------	----------	----------	----------	----------	---------

Series	
Micro-mist compact, 3-unit	16B
Micro-mist standard, 3-unit	17B
Micro-mist compact, 2-unit	16H
Micro-mist standard, 2-unit	17H
Mist compact, 3-unit	06B
Mist standard, 3-unit	07B
Mist compact, 2-unit	06H
Mist standard, 2-unit	07H

Port Size	
1/4 inch (06/16)	1
3/8 inch	2
1/2 inch (06/16 with port blocks)	3
3/4 inch (07/17)	4

Filter Bowl Options	
Poly bowl, metal bowl guard, twist drain	2
Poly bowl, metal bowl guard, auto float drain	6
Metal bowl, twist drain	3
Metal bowl, sight gauge, auto float drain	4
Metal bowl, auto float drain	7
Metal bowl, sight gauge, auto float drain	8

Filter Element	
40 Micron	A
5 Micron	B

Engineering Level	
C	06B, 16B, 06H, 16H current
D	07B, 17B, 07H, 17H current

Lubricator Body Options	
B	With fill plug
F	With body pressure fill

Lubricator Bowl Options	
2	Poly bowl, metal bowl guard, no drain
6	Poly bowl, bowl guard, pressure fill
K	Poly bowl, metal bowl guard, auto fill
N	Poly bowl, metal bowl guard, twist drain
4	Metal bowl, sight gauge, twist drain
8	Metal bowl, sight gauge, pressure fill
M	Metal bowl, sight gauge, auto fill

Relief	
A	Relieving
L	Non-relieving

  

Pressure Range			
Without gauge		With gauge	
11	60 psig	16	60 psig
13	125 psig	18	125 psig
15*	250 psig	21*	250 psig

Modular Options	
Blank	No port blocks
A	with wall mounting bracket & port block
B	with mounting bracket, lockout & port block
C*	with mounting bracket & lockout
G	with port blocks
J	with lockout (no port blocks)
K	with lockout & port blocks
W	with mounting bracket

\* 06/16 Series 1/2" units not available with option C, use option B.

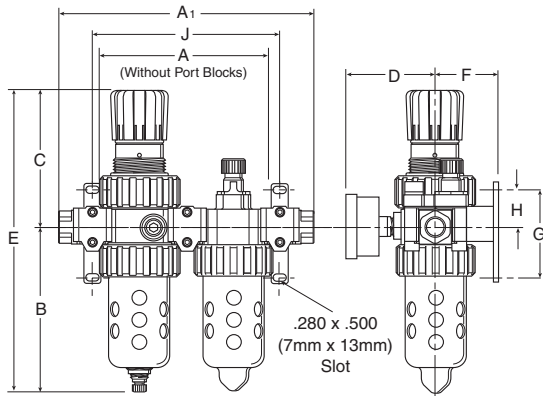

06H, 16H Series

A	A1	B	C	D	E	F	G	H	J
6.10	9.04	5.69	4.69	3.18	10.38	2.00	3.58	1.40	6.65
(155)	(230)	(145)	(119)	(81)	(264)	(51)	(91)	(36)	(169)

07H, 17H Series

A	A1	B	C	D	E	F	G	H	J
7.00	10.28	6.97	4.79	3.44	11.76	2.09	3.58	1.40	7.51
(178)	(261)	(177)	(122)	(87)	(299)	(53)	(91)	(36)	(191)

Inches (mm)

• All dimensions nominal.

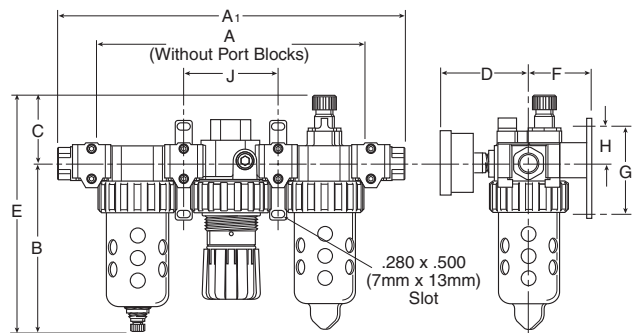

06B, 16B Series

A	A1	B	C	D	E	F	G	H	J
9.46	12.39	5.69	2.24	3.18	7.93	2.00	3.58	1.40	3.33
(240)	(315)	(145)	(57)	(81)	(202)	(51)	(91)	(36)	(85)

07B, 17B Series

A	A1	B	C	D	E	F	G	H	J
10.75	14.03	6.97	2.41	3.44	9.38	2.18	3.58	1.40	3.76
(273)	(356)	(177)	(61)	(87)	(238)	(55)	(91)	(36)	(95)

Inches (mm)

• All dimensions nominal.

Prep-Air® II Products



Filters

Coalescers

Regulators

Filter / Regulators

Lubricators

Combinations

Accessories



**Modular Accessories**

**Service Kits**

Body connector, (05 series)	<b>PS954P</b>
Body connector, (06 series)	<b>PS754P</b>
Body connector, (07 series)	<b>PS854P</b>
Wall mounting kits (05 series)	<b>PS955P</b>
Wall mounting kits (06 & 07 series)	<b>PS755P</b>
Lockout valves, (06 series)	<b>PS756P</b>
Lockout valves, (07 series)	<b>PS856P</b>
Modular manifold block 3/8" port, (06 series)	<b>PS757P</b>
Modular manifold block 1/2" port, (07 series)	<b>PS857P</b>

**Body Connectors**

Body connectors allow you to easily assemble and disassemble modular combinations.

Body connectors are required whenever you assemble two or more pieces together.

Each kit includes one set.

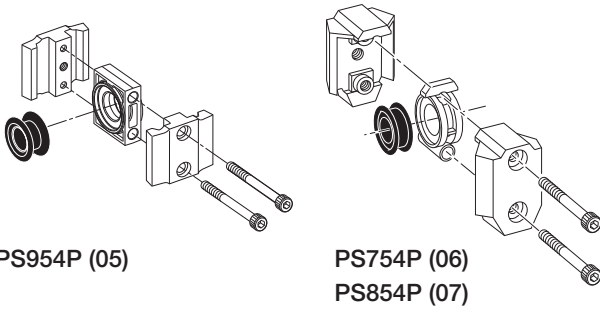

**Modular Manifold Block**

A modular manifold block can be used between any two modular units to give additional outlet ports. The manifold block provides 2 additional outlets in 3/8" and 1/2" sizes. Any standard pipe plug can be used to close off unused ports.

**NOTE: Body connectors are not supplied with manifold blocks.**

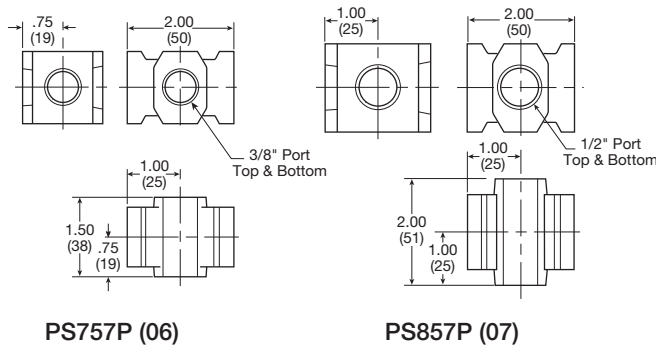
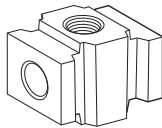

**Lockout Valves**

Lockout Valves provide positive shut-off and exhaust capability to isolate Modular units so they can be easily removed from the line and can be locked in a closed position. Center position can be used as a slow start. Accepts #3 padlock.

**NOTE: Body connectors are not supplied with lockout valves.**

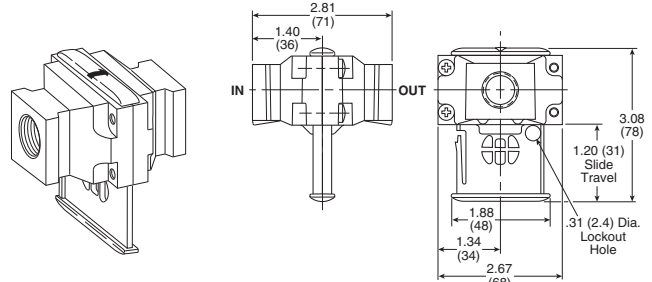

**Wall Mounting Kits**

Wall mounting kits are available for mounting your modular assemblies and can be assembled and used with any standard body connector set.

Since modular combinations are always identical in size, you can predrill for wall mounting on your equipment.

Kit includes 1 assembly.

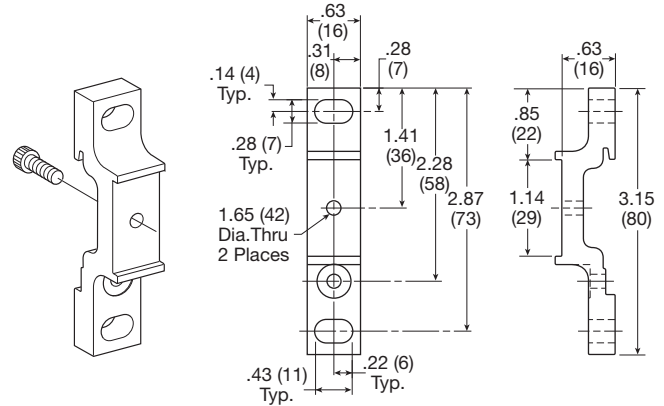

PS955P (05)

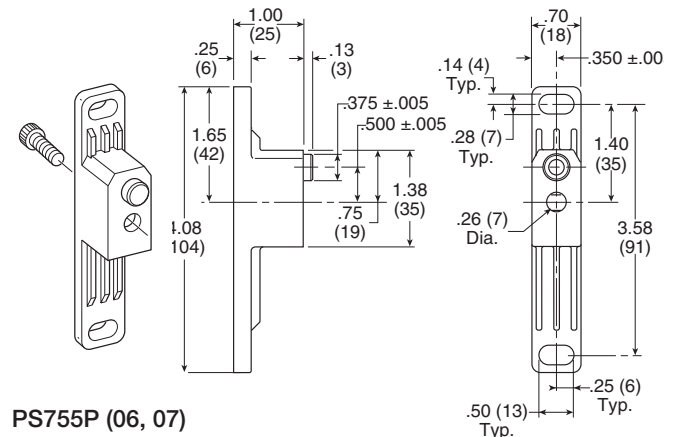

PS755P (06, 07)

Prep-Air® II  
Products



Filters

Coalescers

Regulators

Filter /  
Regulators

Lubricators

Combinations

Accessories



**Modular Accessories – 06 Compact & 07 Standard Series**

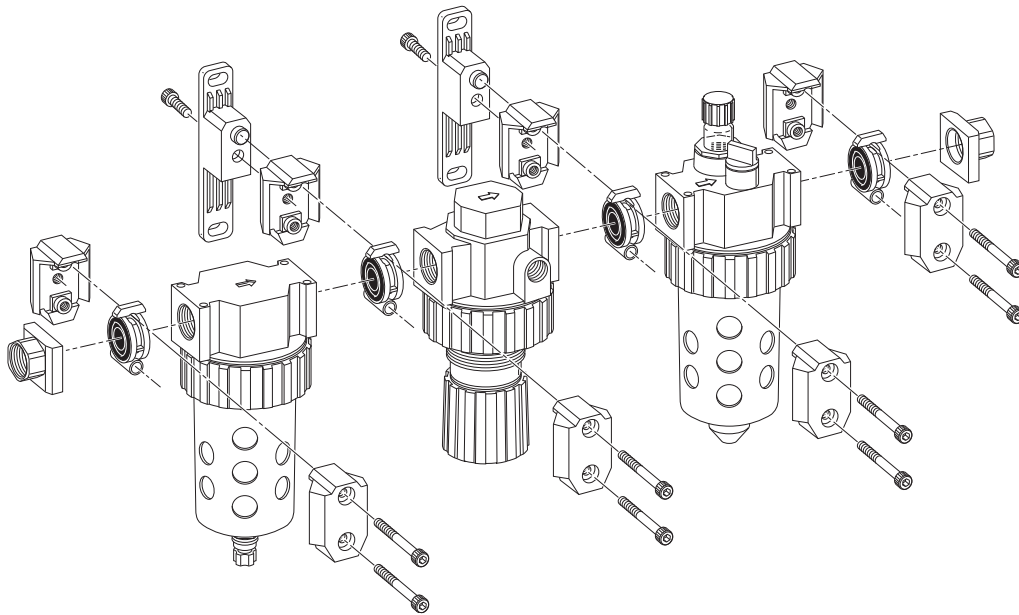

**Port Block Connector Kits**

**06 Series**

1/4" Port block kits, NPT	<b>PS750P</b>
1/4" Port block kits, BSPP	<b>PS765P †</b>
1/4" Port block kits, BSPT	<b>PS761P</b>
3/8" Port block kits, NPT	<b>PS751P</b>
3/8" Port block kits, BSPP	<b>PS766P †</b>
3/8" Port block kits, BSPT	<b>PS762P</b>
1/2" Port block kits, NPT	<b>PS752P*</b>
1/2" Port block kits, BSPP	<b>PS767P* †</b>
1/2" Port block kits, BSPT	<b>PS799P*</b>

**07 Series**

1/4" Port block kits, NPT	<b>PS850P</b>
1/4" Port block kits, BSPP	<b>PS865P</b>
1/4" Port block kits, BSPT	<b>PS861P</b>
3/8" Port block kits, NPT	<b>PS851P</b>
3/8" Port block kits, BSPP	<b>PS866P</b>
3/8" Port block kits, BSPT	<b>PS862P</b>
1/2" Port block kits, NPT	<b>PS852P</b>
1/2" Port block kits, BSPP	<b>PS867P ‡</b>
1/2" Port block kits, BSPT	<b>PS863P</b>
3/4" Port block kits, NPT	<b>PS853P</b>
3/4" Port block kits, BSPP	<b>PS860P</b>
3/4" Port block kits, BSPT	<b>PS864P</b>

\* Use 1/4 or 3/8 ported bodies.

† 1/4, 3/8 & 1/2 inch meet ISO 1179-1 Standard.

‡ 1/2 inch meets ISO 1179-1 Standard.

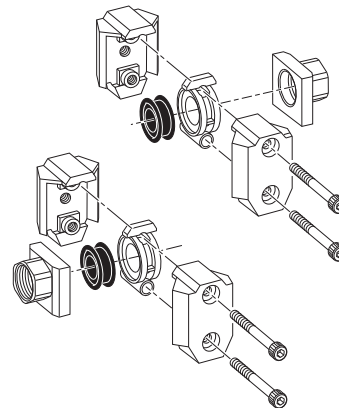

Port block connectors allow you to make threaded port connections to modular units and are available in various port sizes to match your system requirements.

Each kit includes all the necessary pieces to make two port connections.



**06S & 07S Soft Start / Quick Dump Valve**

- Combines Soft Start and Quick Dump Valve in the same body
- Large flow capacities up to 5.7 Cv
- Inline or Modular mounting
- Soft Start flow easily adjusted

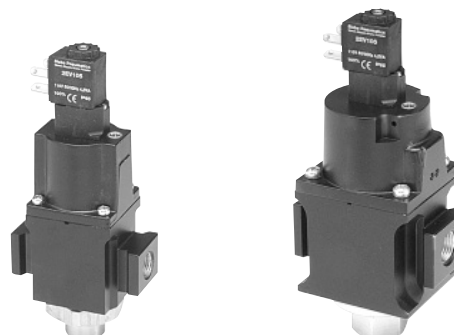
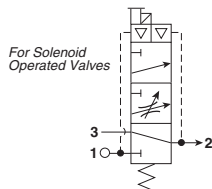

06S

07S

**Operation**

When the valve is installed into the pneumatic system and pilot operator receives no signal, the air is blocked at Port 1. When a pilot signal is received at pilot operator, the valve shifts closing the connection between Ports 2 and 3. At the same time air flow begins between Ports 1 and 2 at a slow rate controlled by the needle valve located on the top of the valve. When the down stream pressure reaches approximately 60% of the supply pressure, the main valve spool opens allowing full flow through the valve into the system. If pilot signal or system pressure is lost, the valve returns to it's initial state venting the down stream pressure through Port 3.

Pressure supply piping must be the same size as the inlet port or larger to insure that the pilot valve receives sufficient pressure supply during high flow conditions.

The valves pilot signal is through a solenoid pilot mounted on the head. The valve should be mounted downstream of the FRL and with the soft start adjustment needle easily accessible.

**⚠ CAUTION: Do not use synthetic, reconstituted, or oils with an alcohol content or detergent additive.**

**⚠ CAUTION: Do not restrict the inlet of valves.**

Port size	Description	Part number
3/8"	24 VDC, 30 to 145 psi	<b>06S249B</b>
3/8"	120/60 Hz, 30 to 145 psi	<b>06S253B</b>
1/2"	24 VDC, 30 to 145 psi	<b>07S349B</b>
1/2"	120/60 Hz, 30 to 145 psi	<b>07S353B</b>

**Operating information**

Exhaust ports:	06S	1/2 inch
	07S	3/4 inch
Inlet and outlet ports:	06S	3/8 inch
	07S	1/2 inch
Maximum pressure:		
Standard coil		145 psig (10.0 bar)
High pressure coil		200 psig (13.8)
Operating pressure (min):		30 psig (20.1 bar)
Operating temperature:		40°F to 120°F (4°C to 49°C)
Weight:	06S	2.25 lb (1.02 kg)
	07S	3.75 lb (1.70 kg)

**Ordering information:**

<b>Series</b>	<b>06S</b>	<b>2</b>	<b>53</b>	<b>B</b>	<b>Option</b>
Soft start / quick dump valve	06S				Blank NPT
Soft start / quick dump valve	07S				1* BSPP G
		<b>Port Size</b>			* 3/8 & 1/2 inch meet ISO 1179-1 standard.
		3/8 inch (06S)	2		
		1/2 inch (07S)	3		
				<b>Engineering Level</b>	
				B	Current
		<b>Operator / Voltage</b>			
		24VDC, 30 to 145 psi	49*		
		120/60 Hz, 30 to 145 psi	53*		
		24VDC, 145 to 200 psi	69†		
		120/60 Hz, 145 to 200 psi	73†		
		M12 Male connector, 4 pole, 24VDC	MD		
		* For voltage options 49 and 53, use 22mm connectors			
		† For voltage options 69 and 73, use 30mm connectors			

Most popular.

Prep-Air® II Products



Filters

Coalescers

Regulators

Filter / Regulators

Lubricators

Combinations

Accessories



## Soft Start / Quick Dump Valve

### Material Specifications

Body	Aluminum
Bottom Plug	Brass

### Repair and Service Kits

06S repair kit	<b>PHRKSC75</b>
07S repair kit	<b>PHRKSC105</b>
06 modular body connectors	<b>PS754P</b>
07 modular body connectors	<b>PS854P</b>
1/2" exhaust silencer	<b>ES50MB</b>
3/4" exhaust silencer	<b>ES75MB</b>

### 22mm Rectangular 3-Pin

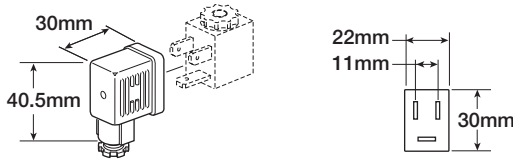

Description	Connector	Connector with 6' (2m) cord
Unlighted	<b>PS2429BP</b>	<b>PS2429JBP</b>
Light – 24VDC	<b>PS243079BP</b>	<b>PS2430J79BP*</b>
Light – 120V/60Hz	<b>PS243083BP</b>	<b>PS2430J83BP*</b>

\* LED with surge suppression.

**Note:** Max ø6.5mm cable size required for connector w/o 6' (2m) cord. IP65 rated when properly installed.

Engineering Data:

Conductors: 2 poles plus ground; Cable range (connector only): 6 to 8mm (0.24 to 0.31 Inch); Contact Spacing: 11mm

### 30mm Square 3-Pin

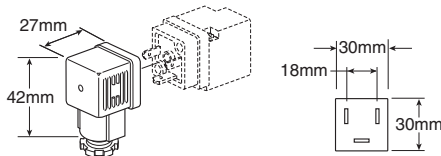

Description	Connector	Connector with 6' (2m) cord
Unlighted	<b>PS2028BP</b>	<b>PS2028JBP</b>
Light – 24VDC	<b>PS203279BP</b>	<b>PS2032J79BP*</b>
Light – 120V/60Hz	<b>PS203283BP</b>	<b>PS2032J83BP*</b>

\* LED with surge suppression.

**Note:** Max ø6.5mm cable size required for connector w/o 6' (2m) cord. IP65 rated when properly installed.

Engineering Data:

Conductors: 2 poles plus ground; Cable range (connector only): 8 to 10mm (0.31 to 0.39 Inch); Contact spacing: 18mm

## Air Preparation Products Prep-Air® II Series

### Performance Characteristics

#### 06S / 07S

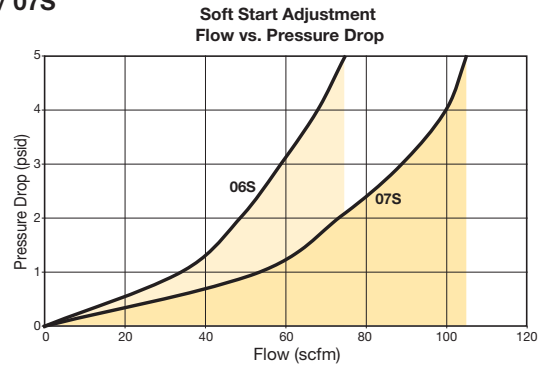

**Table 1:** Shows the relationship between the inlet pressure and downstream pressure at which the main valve opens.

Inlet pressure psig	Downstream pressure psig	
	06S	07S
75	55	52
100	67	68
125	80	82

**Table 2:** Product forward flow Cv and exhaust flow Cv.

Series	Flow Cv	Exhaust flow Cv
06S	4.1	3.4
07S	5.7	4.6

### Connections

#### Central M12 Male Connector, 4 Pole

Pin number	Function	Color
1	24V Supply	Brown
2	0 to 10V or 4 to 20mA Control Signal Ri = 100k Ω	White
3	0V (GND) Supply	Blue
4	24V Alarm Output Signal	Black

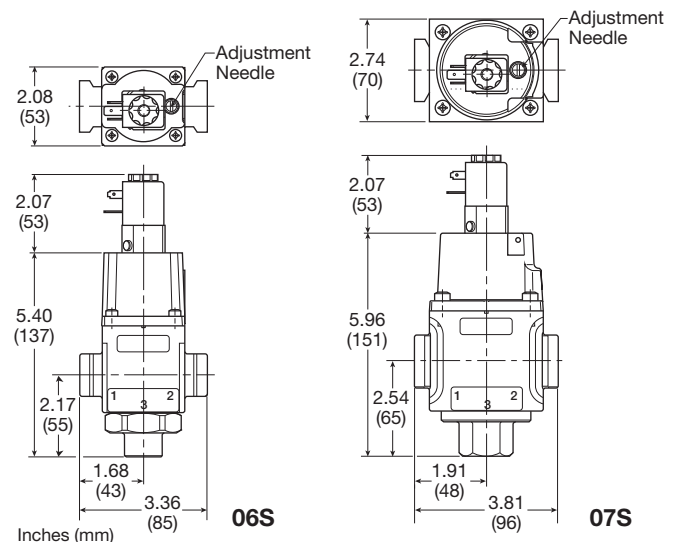
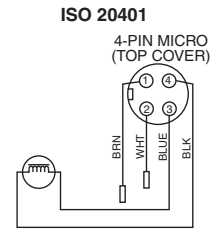

Prep-Air® II Products



Filters

Coalescers

Regulators

Filter / Regulators

Lubricators

Combinations

Accessories



**06T & 07T Solenoid Quick Dump Valve**

- Shuts off incoming pressure while rapidly exhausting downstream pressure
- Large exhaust flow capacities up to 5.0 Cv
- Solenoid operation
- Non-locking manual override
- Inline or Modular Mounting

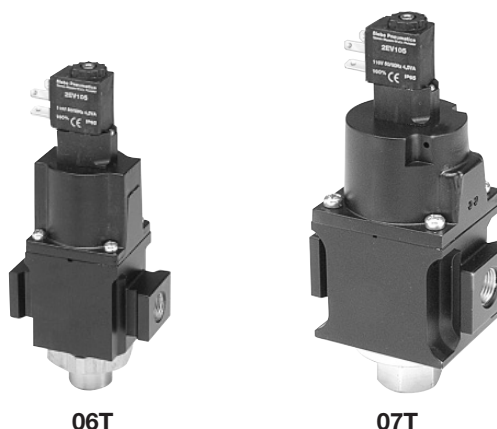
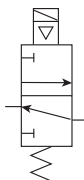

Port size	Description	Part number
3/8"	24 VDC, 30 to 145 psi, NPT	<b>06T249A</b>
3/8"	120/60 Hz, 30 to 145 psi, NPT	<b>06T253A</b>
1/2"	24 VDC, 30 to 145 psi, NPT	<b>07T349A</b>
1/2"	120/60 Hz, 30 to 145 psi, NPT	<b>07T353A</b>

**Operating information**

Exhaust ports:	06T	1/2 inch
	07T	3/4 inch
Inlet and outlet ports:	06T	3/8 inch
	07T	1/2 inch
Maximum pressure:		
Standard coil		145 psig (10.0 bar)
High pressure coil		200 psig (13.8)
Operating pressure (min):		30 psig (20.1 bar)
Operating temperature:		40°F to 120°F (4°C to 49°C)
Weight:	06T	2.25 lb (1.02 kg)
	07T	3.75 lb (1.70 kg)

**Operation**

The solenoid quick dump valves are high flow, normally closed, 3-Port, 2-Position directional control valves.

Upon energizing the solenoid, inlet air is applied to the top of the piston. The piston pushes against the spring and opens the main valve providing full flow air to the downstream. When the solenoid is de-energized, the main valve closes allowing downstream air to exhaust rapidly through the bottom plug. The bottom plug is tapped so that exhaust may be piped away or fitted with a muffler.

**⚠ CAUTION: Do not use synthetic, reconstituted, or oils with an alcohol content or detergent additive.**

**⚠ CAUTION: Do not restrict the inlet of valves having an internal pilot supply. Pressure supply piping must be the same size as the inlet port or larger to insure that the pilot valve receives sufficient pressure supply during high flow conditions.**

**Ordering information:**

<b>06T</b>	<b>2</b>	<b>53</b>	<b>A</b>	<b> </b>																	
<table border="1"> <thead> <tr><th>Series</th></tr> </thead> <tbody> <tr><td>Solenoid quick dump valve 06T</td></tr> <tr><td>Solenoid quick dump valve 07T</td></tr> </tbody> </table>	Series	Solenoid quick dump valve 06T	Solenoid quick dump valve 07T	<table border="1"> <thead> <tr><th>Port Size</th></tr> </thead> <tbody> <tr><td>3/8 inch (06T) 2</td></tr> <tr><td>1/2 inch (07T) 3</td></tr> </tbody> </table>	Port Size	3/8 inch (06T) 2	1/2 inch (07T) 3	<table border="1"> <thead> <tr><th>Operator / Voltage</th></tr> </thead> <tbody> <tr><td>24VDC, 30 to 145 psi 49*</td></tr> <tr><td>120/60 Hz, 30 to 145 psi 53*</td></tr> <tr><td>24VDC, 145 to 200 psi 69†</td></tr> <tr><td>120/60 Hz, 145 to 200 psi 73†</td></tr> <tr><td>M12 Male connector, 4 pole, 24VDC MD</td></tr> </tbody> </table>	Operator / Voltage	24VDC, 30 to 145 psi 49*	120/60 Hz, 30 to 145 psi 53*	24VDC, 145 to 200 psi 69†	120/60 Hz, 145 to 200 psi 73†	M12 Male connector, 4 pole, 24VDC MD	<table border="1"> <thead> <tr><th>Option</th></tr> </thead> <tbody> <tr><td>Blank NPT</td></tr> <tr><td>1* BSPP G</td></tr> </tbody> </table> <p>* 3/8 &amp; 1/2 inch meet ISO 1179-1 standard.</p>	Option	Blank NPT	1* BSPP G	<table border="1"> <thead> <tr><th>Engineering Level</th></tr> </thead> <tbody> <tr><td>A Current</td></tr> </tbody> </table>	Engineering Level	A Current
Series																					
Solenoid quick dump valve 06T																					
Solenoid quick dump valve 07T																					
Port Size																					
3/8 inch (06T) 2																					
1/2 inch (07T) 3																					
Operator / Voltage																					
24VDC, 30 to 145 psi 49*																					
120/60 Hz, 30 to 145 psi 53*																					
24VDC, 145 to 200 psi 69†																					
120/60 Hz, 145 to 200 psi 73†																					
M12 Male connector, 4 pole, 24VDC MD																					
Option																					
Blank NPT																					
1* BSPP G																					
Engineering Level																					
A Current																					

\* For voltage options 49 and 53, use 22mm connectors  
† For voltage options 69 and 73, use 30mm connectors

Most popular.

Prep-Air® II Products  
 Filters  
 Coalescers  
 Regulators  
 Filter / Regulators  
 Lubricators  
 Combinations  
 Accessories





## Solenoid Quick Dump Valve

### Material Specifications

Body	Aluminum
Bottom plug	Brass

### Repair and Service Kits

06T repair kit	PHRKS75
07T repair kit	PHRKS105
06 modular body connectors	PS754P
07 modular body connectors	PS854P
1/2" exhaust silencer	ES50MB
3/4" exhaust silencer	ES75MB

### 22mm Rectangular 3-Pin

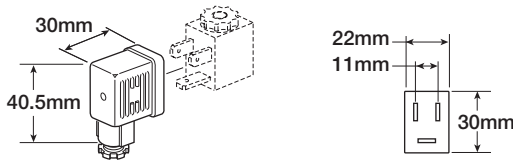

Description	Connector	Connector with 6' (2m) Cord
Unlighted	PS2429BP	PS2429JBP
Light – 24VDC	PS243079BP	PS2430J79BP*
Light – 120V/60Hz	PS243083BP	PS2430J83BP*

\* LED with surge suppression.

**Note:** Max ø6.5 mm cable size required for connector w/o 6' (2m) cord. IP65 rated when properly installed.

Engineering Data:

Conductors: 2 Poles Plus Ground; Cable Range (Connector Only): 6 to 8 mm (0.24 to 0.31 Inch); Contact Spacing: 11mm

### 30mm Square 3-Pin

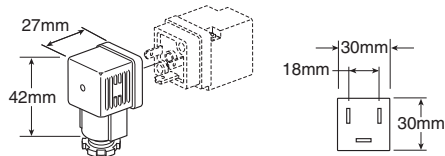

Description	Connector	Connector with 6' (2m) Cord
Unlighted	PS2028BP	PS2028JBP
Light – 24VDC	PS203279BP	PS2032J79BP*
Light – 120V/60Hz	PS203283BP	PS2032J83BP*

\* LED with surge suppression.

**Note:** Max ø6.5 mm cable size required for connector w/o 6' (2m) cord. IP65 rated when properly installed.

Engineering Data:

Conductors: 2 Poles Plus Ground; Cable Range (Connector Only): 8 to 10mm (0.31 to 0.39 Inch); Contact Spacing: 18 mm

## Air Preparation Products Prep-Air® II Series

### Performance Characteristics

#### 06T / 07T

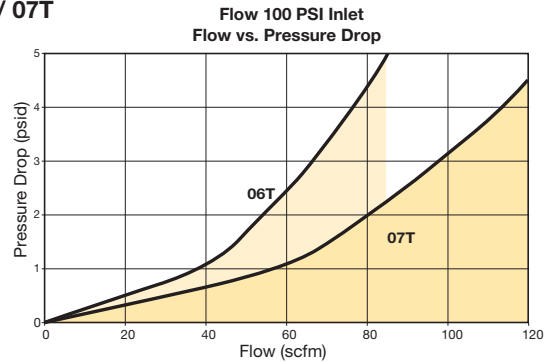

Table 2: Product forward flow Cv (1 to 2).

Series	Flow Cv	Exhaust Flow Cv
06T	3.7	4.1
07T	5.5	5.0

### Connections

#### Central M12 Male Connector, 4 Pole

Pin Number	Function	Color
1	24V Supply	Brown
2	0 to 10V or 4 to 20mA Control Signal Ri = 100k Ω	White
3	0V (GND) Supply	Blue
4	24V Alarm Output Signal	Black

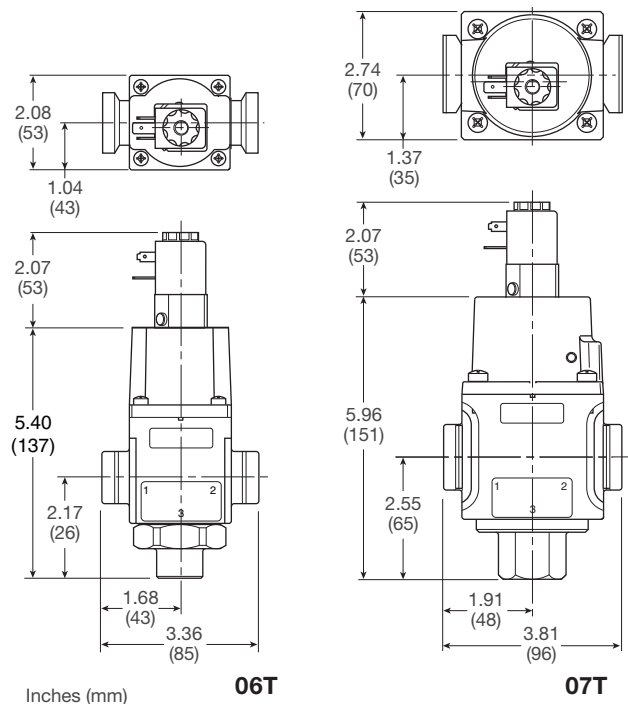
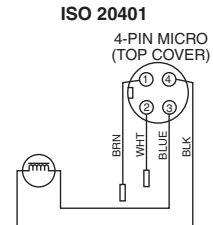

**06P & 07P Auto Pilot Soft Start Valve**

- Smooth start-up of pneumatic system
- Air pilot operation
- Large flow capacities up to 5.5 Cv
- Inline or Modular Mounting

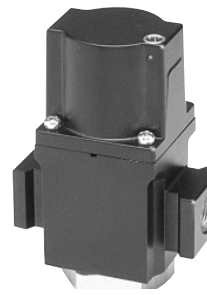
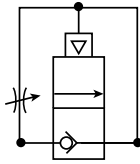

06P



07P

Port size	Description	Part number
3/8"	NPT	<b>06P2A</b>
1/2"	NPT	<b>07P3A</b>

**Operating information**

Maximum pressure:	300 psig (20.7)
Operating pressure (Min):	30 psig (20.1 bar)
Operating temperature:	40°F to 120°F (4°C to 49°C)
Weight:	06P 2.75 lb (1.25 kg) 07P 4.50 lb (2.04 kg)

**Operation**

When pressure is supplied to the inlet port, gradual filling of the downstream system occurs through the adjustable needle valve. The piston opens the main valve when the downstream side of the valve reaches approximately 60% of the supply pressure. The ramp up time to reach the switch over pressure is adjustable via the needle valve in the cover.

The Auto pilot soft start valve is not intended to be used as a shut off valve and should always be placed after a shut off valve.

**CAUTION:** Do not use synthetic, reconstituted, or oils with an alcohol content or detergent additive.

**CAUTION:** Do not restrict the inlet of valves having an internal pilot supply. Pressure supply piping must be the same size as the inlet port or larger to insure that the pilot valve receives sufficient pressure supply during high flow conditions.

**Ordering information:**

<b>06P</b>	<b>2</b>	<b>A</b>	□											
<table border="1"> <thead> <tr><th>Series</th></tr> </thead> <tbody> <tr><td>Auto pilot soft start valve 06P</td></tr> <tr><td>Auto pilot soft start valve 07P</td></tr> </tbody> </table>	Series	Auto pilot soft start valve 06P	Auto pilot soft start valve 07P	<table border="1"> <thead> <tr><th>Port Size</th></tr> </thead> <tbody> <tr><td>3/8 inch (06P) 2</td></tr> <tr><td>1/2 inch (07P) 3</td></tr> </tbody> </table>	Port Size	3/8 inch (06P) 2	1/2 inch (07P) 3	<table border="1"> <thead> <tr><th>Engineering Level</th></tr> </thead> <tbody> <tr><td>A Current</td></tr> </tbody> </table>	Engineering Level	A Current	<table border="1"> <thead> <tr><th>Option</th></tr> </thead> <tbody> <tr><td>Blank NPT</td></tr> <tr><td>1* BSPP G</td></tr> </tbody> </table> <p>* 3/8 &amp; 1/2 inch meet ISO 1179-1 standard.</p>	Option	Blank NPT	1* BSPP G
Series														
Auto pilot soft start valve 06P														
Auto pilot soft start valve 07P														
Port Size														
3/8 inch (06P) 2														
1/2 inch (07P) 3														
Engineering Level														
A Current														
Option														
Blank NPT														
1* BSPP G														

□ Most popular.

Prep-Air® II Products  
 Filters  
 Coalescers  
 Regulators  
 Filter / Regulators  
 Lubricators  
 Combinations  
 Accessories



## Auto Pilot Soft Start Valve

### Material Specifications

Body	Aluminum
Bottom plug, 06P	Brass
Bottom plug, 07P	Zinc

### Repair and Service Kits

06P repair kit	<b>PHRKSS75</b>
07P repair kit	<b>PHRKSS105</b>
06 modular body connectors	<b>PS754P</b>
07 modular body connectors	<b>PS854P</b>

## Air Preparation Products Prep-Air® II Series

### Performance Characteristics

#### 06P / 07P

Soft Start Adjustment  
Flow vs. Pressure Drop

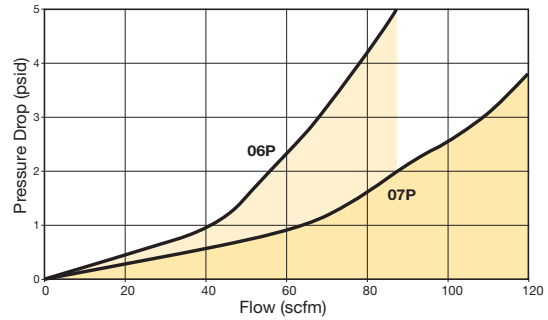
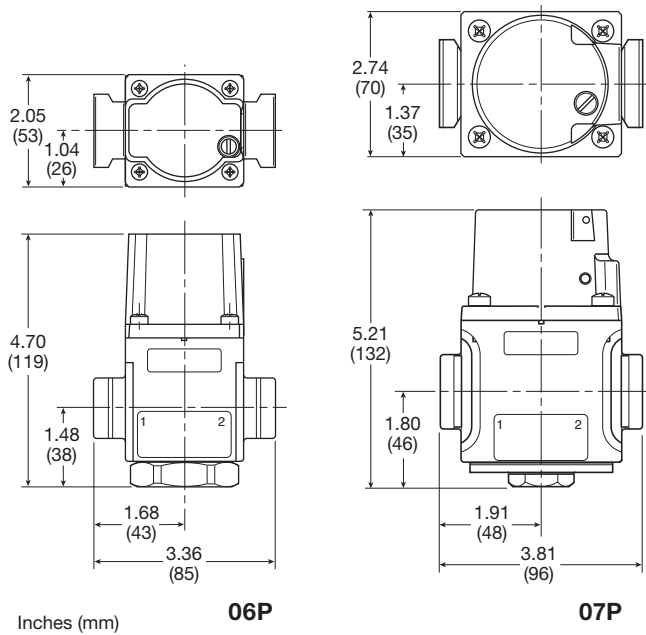

**Table 1:** Shows the relationship between the inlet pressure and downstream pressure at which the main valve opens.

Inlet Pressure psig	Downstream Pressure psig	
	06P	07P
75	45	25
100	60	33
125	75	38
150	85	45

**Table 2:** Product forward flow Cv (1 to 2).

Series	Flow Cv
06P	3.8
07P	5.5



Mounting Bracket Kits

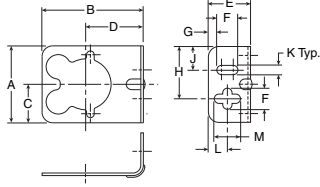

**PS417BP**  
(Includes Panel Mount Nut)

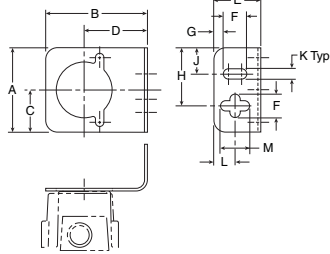

**PS419**  
(Includes Panel Mount Nut)

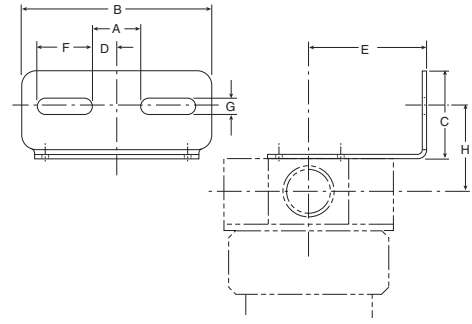

**PS743P, PS843P**

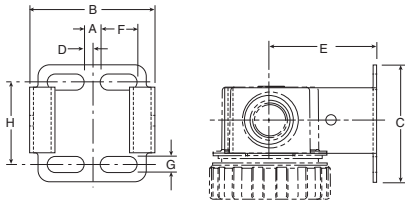

**PS943P**

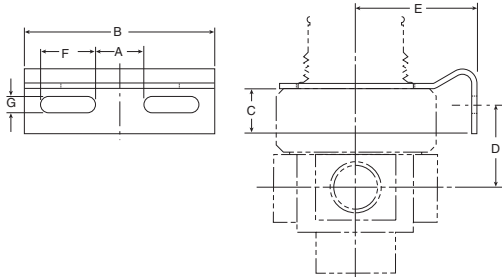

**PS707P & PS807P**  
(Includes Panel Mount Nut)

**PS963P**  
(Includes Aluminum Panel Mount Nut)

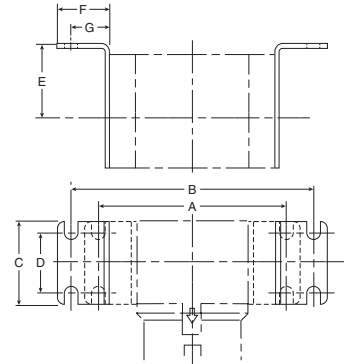

**P3NKA00MW**

Dimensions

A	B	C	D	E	F	G	H	J	K	L	M	Kit
1.80 (46)	2.37 (60)	0.90 (23)	1.35 (34)	1.00 (25)	0.50 (13)	0.20 (5)	1.24 (31)	0.56 (14)	0.22 (6)	0.45 (11)	0.62 (16)	<b>PS417BP</b> (10F, 14F, P3A, 14R, 14E)
1.80 (46)	2.17 (55)	0.90 (23)	1.35 (34)	1.00 (25)	0.50 (13)	0.20 (5)	1.24 (31)	0.56 (14)	0.22 (6)	0.45 (11)	0.62 (16)	<b>PS419</b> (04L)
0.84 (21)	3.25 (83)	1.50 (38)	0.42 (11)	2.00 (51)	0.94 (24)	0.28 (7)	1.44 (37)	—	—	—	—	<b>PS743P</b> (06F, 11F, 06L, 16L)
1.00 (25)	3.94 (100)	1.57 (40)	0.50 (13)	2.19 (56)	1.25 (32)	0.28 (7)	1.68 (43)	—	—	—	—	<b>PS843P</b> (07F, 12F, 07L, 17L)
0.28 (7)	2.12 (54)	2.00 (51)	0.14 (4)	1.85 (47)	0.63 (16)	0.28 (7)	1.41 (36)	—	—	—	—	<b>PS943P</b> (05F, 15F, 15L)
0.84 (21)	2.59 (66)	0.49 (12)	1.02 (26)	1.85 (47)	0.61 (15)	0.28 (7)	—	—	—	—	—	<b>PS963P</b> (05R, 10R, 05E, 27E)
0.84 (21)	3.26 (83)	0.77 (20)	1.46 (37)	2.00 (51)	0.94 (24)	0.28 (7)	—	—	—	—	—	<b>PS707P</b> (06R, 06E, 11R)
1.00 (25)	3.94 (100)	0.65 (17)	1.68 (43)	2.19 (56)	1.25 (32)	0.28 (7)	—	—	—	—	—	<b>PS807P</b> (07R, 07E, 12R)
6.22 (158)	8.19 (208)	2.75 (70)	1.97 (50)	2.36 (60)	1.77 (45)	1.30 (33)	—	—	—	—	—	P3NKA00MW (P3NF, P3NR, P3NE, P3NL)

inches (mm)

Prep-Air® II  
Products



Filters

Coalescers

Regulators

Filter /  
Regulators

Lubricators

Combinations

Accessories



## Remote Auto-Fill Device

- Wide operating range (oil supply to inlet may be 30 to 270 psig; air operating pressure depends on bowl used)
- Rugged polyurethane float design
- Complete field conversion kit (internal components only)
- Adaptable on polycarbonate and metal bowls already in service (must supply lubricator housing in order to retrofit)
- Oil supply strainer standard
- Fits 06L / 16L and 07L / 17L series
- 3/8", 1/2", 3/4" ports

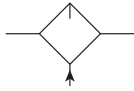

Description	Weight lbs (kg)	Part number
Auto-fill device kit	1.9 (0.9)	PS505CP

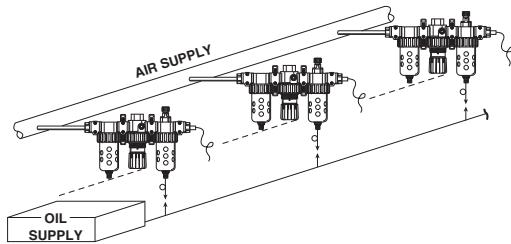

### Operation

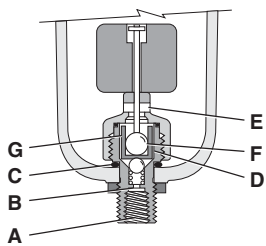

Oil enters the unit at the pipe thread fitting (A) with a supply pressure that is a minimum of 20 psig above the lubricator air pressure. With the float lowered, oil flows through metering orifice (B) and lifts the check ball (C). Oil continues to flow past the shuttle chamber annulus (D) and out the cross drilled hole (E). As the oil level rises, it cause the float to rise to its maximum level in the bowl. During this period the shut-off ball (F) remains in chamber (G), out of the flow stream. Near the end of the filling period, shut-off ball (F) will enter the flow stream and snap shut against the seat in chamber (G).

The stem assembly will thus block any additional oil passage as long as the oil supply pressure is maintained at (A). When the supply pressure at (A) is released, ball (C) is held up against the shuttle (D) by a spring causing a slight delay in reverse flow shut-off. This permits the higher still present supply pressure in chamber (G) to dissipate and bowl pressure to take over. The shuttle then moves down forcing ball (C) to close orifice (B). The orifice will remain closed as long as there is air pressure in the bowl.

This delay of reverse flow in chamber (G) is necessary to allow shut-off ball (F) to fall when the oil level decreases and permit oil to enter the bowl for the next refill. Thus, for the unit to operate properly, it is necessary that the oil supply pressure go to zero after each fill.

Most popular.



### Operating information

Supply pressure (max):	
Plastic bowl	150 psig (10.3 bar)
Metal bowl / sight gauge	250 psig (17.2 bar)
Operating temperature:	
Plastic bowl	32°F to 125°F (0°C to 52°C)
Metal bowl / sight gauge	32°F to 175°F (0°C to 80°C)
Flow capacity†:	
Minimum flow	1 scfm (0.5 dm³/s, ANR) at 100 psig
Bowl capacity:	4.9 oz.

† Oil inlet pressure must be at least 20 psig above system air pressure and may be up to 300 psig.

### Material Specifications

Body, cap & stem	Aluminum
Float	Polyurethane
Mounting nut	Delrin
Seals	Nitrile
Spring	Stainless

Flexible tubing is recommended for oil supply line connection to remote fill inlet. Rigid piping should be avoided to prevent possible damage due to stresses on the lubricator bowl assembly.

Oil supply line should be pressurized for 2 to 15 minutes one or more times per day. Pressurization frequently should be based on maintaining oil in lubricator at its highest level.

**Suggested Lubricant** ..... **F442 Oil**  
Petroleum based oil of 100 to 200 SUS viscosity at 38°C (100°F) and an aniline point greater than 93°C (200°F)  
(DO NOT USE OILS WITH ADDITIVES, COMPOUNDED OILS CONTAINING SOLVENTS, GRAPHITE, DETERGENTS, OR SYNTHETIC OILS.)

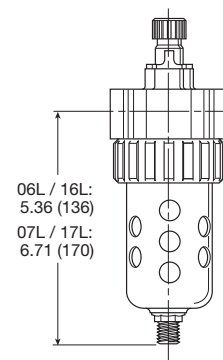

Inches (mm)

Prep-Air® II  
Products



Filters

Coalescers

Regulators

Filter/  
Regulators

Lubricators

Combinations

Accessories

# Safety Guide For Selecting And Using Pneumatic Division Products And Related Accessories

## WARNING:

**FAILURE OR IMPROPER SELECTION OR IMPROPER USE OF PNEUMATIC DIVISION PRODUCTS, ASSEMBLIES OR RELATED ITEMS ("PRODUCTS") CAN CAUSE DEATH, PERSONAL INJURY, AND PROPERTY DAMAGE. POSSIBLE CONSEQUENCES OF FAILURE OR IMPROPER SELECTION OR IMPROPER USE OF THESE PRODUCTS INCLUDE BUT ARE NOT LIMITED TO:**

- Unintended or mistimed cycling or motion of machine members or failure to cycle
- Work pieces or component parts being thrown off at high speeds.
- Failure of a device to function properly for example, failure to clamp or unclamp an associated item or device.
- Explosion
- Suddenly moving or falling objects.
- Release of toxic or otherwise injurious liquids or gasses.

Before selecting or using any of these Products, it is important that you read and follow the instructions below.

## 1. GENERAL INSTRUCTIONS

- 1.1. Scope:** This safety guide is designed to cover general guidelines on the installation, use, and maintenance of Pneumatic Division Valves, FRLs (Filters, Pressure Regulators, and Lubricators), Vacuum products and related accessory components.
- 1.2. Fail-Safe:** Valves, FRLs, Vacuum products and their related components can and do fail without warning for many reasons. Design all systems and equipment in a fail-safe mode, so that failure of associated valves, FRLs or Vacuum products will not endanger persons or property.
- 1.3 Relevant International Standards:** For a good guide to the application of a broad spectrum of pneumatic fluid power devices see: ISO 4414:1998, Pneumatic Fluid Power – General Rules Relating to Systems. See [www.iso.org](http://www.iso.org) for ordering information.
- 1.4. Distribution:** Provide a copy of this safety guide to each person that is responsible for selection, installation, or use of Valves, FRLs or Vacuum products. Do not select, or use Parker valves, FRLs or vacuum products without thoroughly reading and understanding this safety guide as well as the specific Parker publications for the products considered or selected.
- 1.5. User Responsibility:** Due to the wide variety of operating conditions and applications for valves, FRLs, and vacuum products Parker and its distributors do not represent or warrant that any particular valve, FRL or vacuum product is suitable for any specific end use system. This safety guide does not analyze all technical parameters that must be considered in selecting a product. The user, through its own analysis and testing, is solely responsible for:
  - Making the final selection of the appropriate valve, FRL, Vacuum component, or accessory.
  - Assuring that all user's performance, endurance, maintenance, safety, and warning requirements are met and that the application presents no health or safety hazards.
  - Complying with all existing warning labels and / or providing all appropriate health and safety warnings on the equipment on which the valves, FRLs or Vacuum products are used; and,
  - Assuring compliance with all applicable government and industry standards.
- 1.6. Safety Devices:** Safety devices should not be removed, or defeated.
- 1.7. Warning Labels:** Warning labels should not be removed, painted over or otherwise obscured.
- 1.8. Additional Questions:** Call the appropriate Parker technical service department if you have any questions or require any additional information. See the Parker publication for the product being considered or used, or call 1-800-CPARKER, or go to [www.parker.com](http://www.parker.com), for telephone numbers of the appropriate technical service department.

## 2. PRODUCT SELECTION INSTRUCTIONS

- 2.1. Flow Rate:** The flow rate requirements of a system are frequently the primary consideration when designing any pneumatic system. System components need to be able to provide adequate flow and pressure for the desired application.
- 2.2. Pressure Rating:** Never exceed the rated pressure of a product. Consult product labeling, Pneumatic Division catalogs or the instruction sheets supplied for maximum pressure ratings.
- 2.3. Temperature Rating:** Never exceed the temperature rating of a product. Excessive heat can shorten the life expectancy of a product and result in complete product failure.
- 2.4. Environment:** Many environmental conditions can affect the integrity and suitability of a product for a given application. Pneumatic Division products are designed for use in general purpose industrial applications. If these products are to be used in unusual circumstances such as direct sunlight and/or corrosive or caustic environments, such use can shorten the useful life and lead to premature failure of a product.
- 2.5. Lubrication and Compressor Carryover:** Some modern synthetic oils can and will attack nitrile seals. If there is any possibility of synthetic oils or greases migrating into the pneumatic components check for compatibility with the seal materials used. Consult the factory or product literature for materials of construction.
- 2.6. Polycarbonate Bowls and Sight Glasses:** To avoid potential polycarbonate bowl failures:
  - Do not locate polycarbonate bowls or sight glasses in areas where they could be subject to direct sunlight, impact blow, or temperatures outside of the rated range.
  - Do not expose or clean polycarbonate bowls with detergents, chlorinated hydro-carbons, ketones, esters or certain alcohols.
  - Do not use polycarbonate bowls or sight glasses in air systems where compressors are lubricated with fire resistant fluids such as phosphate ester and di-ester lubricants.

Part Number  
Index

Safety Guide

Offer of Sale

Part Number Index,  
Safety Guide, Offer of Sale





**2.7. Chemical Compatibility:** For more information on plastic component chemical compatibility see Pneumatic Division technical bulletins Tec-3, Tec-4, and Tec-5

- 2.8. Product Rupture:** Product rupture can cause death, serious personal injury, and property damage.
- Do not connect pressure regulators or other Pneumatic Division products to bottled gas cylinders.
  - Do not exceed the maximum primary pressure rating of any pressure regulator or any system component.
  - Consult product labeling or product literature for pressure rating limitations.

**3. PRODUCT ASSEMBLY AND INSTALLATION INSTRUCTIONS**

- 3.1. Component Inspection:** Prior to assembly or installation a careful examination of the valves, FRLs or vacuum products must be performed. All components must be checked for correct style, size, and catalog number. DO NOT use any component that displays any signs of nonconformance.
- 3.2. Installation Instructions:** Parker published Installation Instructions must be followed for installation of Parker valves, FRLs and vacuum components. These instructions are provided with every Parker valve or FRL sold, or by calling 1-800-CPARKER, or at [www.parker.com](http://www.parker.com).
- 3.3. Air Supply:** The air supply or control medium supplied to Valves, FRLs and Vacuum components must be moisture-free if ambient temperature can drop below freezing

**4. VALVE AND FRL MAINTENANCE AND REPLACEMENT INSTRUCTIONS**

- 4.1. Maintenance:** Even with proper selection and installation, valve, FRL and vacuum products service life may be significantly reduced without a continuing maintenance program. The severity of the application, risk potential from a component failure, and experience with any known failures in the application or in similar applications should determine the frequency of inspections and the servicing or replacement of Pneumatic Division products so that products are replaced before any failure occurs. A maintenance program must be established and followed by the user and, at minimum, must include instructions 4.2 through 4.9.
- 4.2. Installation and Service Instructions:** Before attempting to service or replace any worn or damaged parts consult the appropriate Service Bulletin for the valve or FRL in question for the appropriate practices to service the unit in question. These Service and Installation Instructions are provided with every Parker valve and FRL sold, or are available by calling 1-800-CPARKER, or by accessing the Parker web site at [www.parker.com](http://www.parker.com).
- 4.3. Lockout / Tagout Procedures:** Be sure to follow all required lockout and tagout procedures when servicing equipment. For more information see: OSHA Standard – 29 CFR, Part 1910.147, Appendix A, The Control of Hazardous Energy – (Lockout / Tagout)
- 4.4. Visual Inspection:** Any of the following conditions requires immediate system shut down and replacement of worn or damaged components:
- Air leakage: Look and listen to see if there are any signs of visual damage to any of the components in the system. Leakage is an indication of worn or damaged components.
  - Damaged or degraded components: Look to see if there are any visible signs of wear or component degradation.
  - Kinked, crushed, or damaged hoses. Kinked hoses can result in restricted air flow and lead to unpredictable system behavior.
  - Any observed improper system or component function: Immediately shut down the system and correct malfunction.
  - Excessive dirt build-up: Dirt and clutter can mask potentially hazardous situations.

**Caution: Leak detection solutions should be rinsed off after use.**

- 4.5. Routine Maintenance Issues:**
- Remove excessive dirt, grime and clutter from work areas.
  - Make sure all required guards and shields are in place.
- 4.6. Functional Test:** Before initiating automatic operation, operate the system manually to make sure all required functions operate properly and safely.
- 4.7. Service or Replacement Intervals:** It is the user's responsibility to establish appropriate service intervals. Valves, FRLs and vacuum products contain components that age, harden, wear, and otherwise deteriorate over time. Environmental conditions can significantly accelerate this process. Valves, FRLs and vacuum components need to be serviced or replaced on routine intervals. Service intervals need to be established based on:
- Previous performance experiences.
  - Government and / or industrial standards.
  - When failures could result in unacceptable down time, equipment damage or personal injury risk.
- 4.8. Servicing or Replacing of any Worn or Damaged Parts:** To avoid unpredictable system behavior that can cause death, personal injury and property damage:
- Follow all government, state and local safety and servicing practices prior to service including but not limited to all OSHA Lockout Tagout procedures (OSHA Standard – 29 CFR, Part 1910.147, Appendix A, The Control of Hazardous Energy – Lockout / Tagout).
  - Disconnect electrical supply (when necessary) before installation, servicing, or conversion.
  - Disconnect air supply and depressurize all air lines connected to system and Pneumatic Division products before installation, service, or conversion.
  - Installation, servicing, and / or conversion of these products must be performed by knowledgeable personnel who understand how pneumatic products are to be applied.
  - After installation, servicing, or conversions air and electrical supplies (when necessary) should be connected and the product tested for proper function and leakage. If audible leakage is present, or if the product does not operate properly, do not put product or system into use.
  - Warnings and specifications on the product should not be covered or painted over. If masking is not possible, contact your local representative for replacement labels.
- 4.9. Putting Serviced System Back into Operation:** Follow the guidelines above and all relevant Installation and Maintenance Instructions supplied with the valve FRL or vacuum component to insure proper function of the system.

Part Number  
Index

Safety Guide

Offer of Sale

Part Number Index,  
Safety Guide, Offer of Sale





The goods, services or work (referred to as the “Products”) offered by **Parker-Hannifin Corporation**, its subsidiaries, groups, divisions, and authorized distributors (“Seller”) are offered for sale at prices indicated in the offer, or as may be established by Seller. The offer to sell the Products and acceptance of Seller’s offer by any customer (“Buyer”) is contingent upon, and will be governed by all of the terms and conditions contained in this Offer of Sale. Buyer’s order for any Products specified in Buyer’s purchase document or Seller’s offer, proposal or quote (“Quote”) attached to the purchase order, when communicated to Seller verbally, or in writing, shall constitute acceptance of this offer.

- 1. Terms and Conditions.** Seller’s willingness to offer Products for sale or accept an order for Products is subject to the terms and conditions contained in this Offer of Sale or any newer version of the same, published by Seller electronically at [www.parker.com/saleterms/](http://www.parker.com/saleterms/). Seller objects to any contrary or additional terms or conditions of Buyer’s order or any other document or other communication issued by Buyer.
- 2. Price; Payment.** Prices stated on Seller’s Quote are valid for thirty (30) days, except as explicitly otherwise stated therein, and do not include any sales, use, or other taxes or duties unless specifically stated. Seller reserves the right to modify prices to adjust for any raw material price fluctuations. Unless otherwise specified by Seller, all prices are F.C.A. Seller’s facility (INCOTERMS 2010). Payment is subject to credit approval and payment for all purchases is due thirty (30) days from the date of invoice (or such date as may be specified by Seller’s Credit Department). Unpaid invoices beyond the specified payment date incur interest at the rate of 1.5% per month or the maximum allowable rate under applicable law.
- 3. Shipment; Delivery; Title and Risk of Loss.** All delivery dates are approximate. Seller is not responsible for damages resulting from any delay. Regardless of the manner of shipment, delivery occurs and title and risk of loss or damage pass to Buyer, upon placement of the Products with the shipment carrier at Seller’s facility. Unless otherwise stated, Seller may exercise its judgment in choosing the carrier and means of delivery. No deferral of shipment at Buyers’ request beyond the respective dates indicated will be made except on terms that will indemnify, defend and hold Seller harmless against all loss and additional expense. Buyer shall be responsible for any additional shipping charges incurred by Seller due to Buyer’s acts or omissions.
- 4. Warranty.** Seller warrants that the Products sold hereunder shall be free from defects in material or workmanship for a period of twelve (12) months from the date of delivery or 2,000 hours of normal use, whichever occurs first. All prices are based upon the exclusive limited warranty stated above, and upon the following disclaimer: **DISCLAIMER OF WARRANTY: THIS WARRANTY IS THE SOLE AND ENTIRE WARRANTY PERTAINING TO PRODUCTS PROVIDED. SELLER DISCLAIMS ALL OTHER WARRANTIES, EXPRESS AND IMPLIED, INCLUDING DESIGN, MERCHANTABILITY AND FITNESS FOR A PARTICULAR PURPOSE.**
- 5. Claims; Commencement of Actions.** Buyer shall promptly inspect all Products upon receipt. No claims for shortages will be allowed unless reported to the Seller within ten (10) days of delivery. No other claims against Seller will be allowed unless asserted in writing within thirty (30) days after delivery. Buyer shall notify Seller of any alleged breach of warranty within thirty (30) days after the date the defect is or should have been discovered by Buyer. Any claim or action against Seller based upon breach of contract or any other theory, including tort, negligence, or otherwise must be commenced within twelve (12) months from the date of the alleged breach or other alleged event, without regard to the date of discovery.
- 6. LIMITATION OF LIABILITY.** IN THE EVENT OF A BREACH OF WARRANTY, SELLER WILL, AT ITS OPTION, REPAIR OR REPLACE A DEFECTIVE PRODUCT, OR REFUND THE PURCHASE PRICE WITHIN A REASONABLE PERIOD OF TIME. **IN NO EVENT IS SELLER LIABLE FOR ANY SPECIAL, INDIRECT, INCIDENTAL OR CONSEQUENTIAL DAMAGES ARISING OUT OF, OR AS THE RESULT OF, THE SALE, DELIVERY, NON-DELIVERY, SERVICING, USE OR LOSS OF USE OF THE PRODUCTS OR ANY PART THEREOF, OR FOR ANY CHARGES OR EXPENSES OF ANY NATURE INCURRED WITHOUT SELLER’S WRITTEN CONSENT, WHETHER BASED IN CONTRACT, TORT OR OTHER LEGAL THEORY. IN NO EVENT SHALL SELLER’S LIABILITY UNDER ANY CLAIM MADE BY BUYER EXCEED THE PURCHASE PRICE OF THE PRODUCTS.**
- 7. User Responsibility.** The user, through its own analysis and testing, is solely responsible for making the final selection of the system and Product and assuring that all performance, endurance, maintenance, safety and warning requirements of the application are met. The user must analyze all aspects of the application and follow applicable industry standards and Product information. If Seller provides Product or system options based upon data or specifications provided by the user, the user is responsible for determining that such data and specifications are suitable and sufficient for all applications and reasonably foreseeable uses of the Products or systems.
- 8. Loss to Buyer’s Property.** Any designs, tools, patterns, materials, drawings, confidential information or equipment furnished by Buyer or any other items which become Buyer’s property, will be considered obsolete and may be destroyed by Seller after two (2) consecutive years have elapsed without Buyer ordering the items manufactured using such property. Seller shall not be responsible for any loss or damage to such property while it is in Seller’s possession or control.
- 9. Special Tooling.** A tooling charge may be imposed for any special tooling, including without limitation, dies, fixtures, molds and patterns, acquired to manufacture Products. Such special tooling shall be and remain Seller’s property notwithstanding payment of any charges by Buyer. In no event will Buyer acquire any interest in apparatus belonging to Seller which is utilized in the manufacture of the Products, even if such apparatus has been specially converted or adapted for such manufacture and notwithstanding any charges paid by Buyer. Unless otherwise agreed, Seller has the right to alter, discard or otherwise dispose of any special tooling or other property in its sole discretion at any time.
- 10. Buyer’s Obligation; Rights of Seller.** To secure payment of all sums due or otherwise, Seller retains a security interest in all Products delivered to Buyer and this agreement is deemed to be a Security Agreement under the Uniform Commercial Code. Buyer authorizes Seller as its attorney to execute and file on Buyer’s behalf all documents Seller deems necessary to perfect its security interest.
- 11. Improper Use and Indemnity.** Buyer shall indemnify, defend, and hold Seller harmless from any losses, claims, liabilities, damages, lawsuits, judgments and costs

- (including attorney fees and defense costs), whether for personal injury, property damage, patent, trademark or copyright infringement or any other claim, brought by or incurred by Buyer, Buyer’s employees, or any other person, arising out of: (a) improper selection, application, design, specification or other misuse of Products purchased by Buyer from Seller; (b) any act or omission, negligent or otherwise, of Buyer; (c) Seller’s use of patterns, plans, drawings, or specifications furnished by Buyer to manufacture Products; or (d) Buyer’s failure to comply with these terms and conditions. Seller shall not indemnify Buyer under any circumstance except as otherwise provided.
- 12. Cancellations and Changes.** Buyer may not cancel or modify or cancel any order for any reason, except with Seller’s written consent and upon terms that will indemnify, defend and hold Seller harmless against all direct, incidental and consequential loss or damage. Seller may change Product features, specifications, designs and availability.
  - 13. Limitation on Assignment.** Buyer may not assign its rights or obligations under this agreement without the prior written consent of Seller.
  - 14. Force Majeure.** Seller does not assume the risk and is not liable for delay or failure to perform any of Seller’s obligations by reason of events or circumstances beyond its reasonable control (hereinafter “Events of Force Majeure”). Events of Force Majeure shall include without limitation: accidents, strikes or labor disputes, acts of any government or government agency, acts of nature, delays or failures in delivery from carriers or suppliers, shortages of materials, or any other cause beyond Seller’s reasonable control.
  - 15. Waiver and Severability.** Failure to enforce any provision of this agreement will not invalidate that provision; nor will any such failure prejudice Seller’s right to enforce that provision in the future. Invalidation of any provision of this agreement by legislation or other rule of law shall not invalidate any other provision herein. The remaining provisions of this agreement will remain in full force and effect.
  - 16. Termination.** Seller may terminate this agreement for any reason and at any time by giving Buyer thirty (30) days prior written notice. Seller may immediately terminate this agreement, in writing, if Buyer: (a) breaches any provision of this agreement (b) appoints a trustee, receiver or custodian for all or any part of Buyer’s property (c) files a petition for relief in bankruptcy on its own behalf, or one if filed by a third party (d) makes an assignment for the benefit of creditors; or (e) dissolves its business or liquidates all or a majority of its assets.
  - 17. Governing Law.** This agreement and the sale and delivery of all Products are deemed to have taken place in, and shall be governed and construed in accordance with, the laws of the State of Ohio, as applicable to contracts executed and wholly performed therein and without regard to conflicts of laws principles. Buyer irrevocably agrees and consents to the exclusive jurisdiction and venue of the courts of Cuyahoga County, Ohio with respect to any dispute, controversy or claim arising out of or relating to this agreement.
  - 18. Indemnity for Infringement of Intellectual Property Rights.** Seller is not liable for infringement of any patents, trademarks, copyrights, trade dress, trade secrets or similar rights except as provided in this Section. Seller will defend and indemnify Buyer against allegations of infringement of U.S. patents, U.S. trademarks, copyrights, trade dress and trade secrets (“Intellectual Property Rights”). Seller will defend at its expense and will pay the cost of any settlement or damages awarded in an action brought against Buyer based on an allegation that a Product sold pursuant to this agreement infringes the Intellectual Property Rights of a third party. Seller’s obligation to defend and indemnify Buyer is contingent on Buyer notifying Seller within ten (10) days after Buyer becomes aware of such allegations of infringement, and Seller having sole control over the defense of any allegations or actions including all negotiations for settlement or compromise. If a Product is subject to a claim that it infringes the Intellectual Property Rights of a third party, Seller may, at its sole expense and option, procure for Buyer the right to continue using the Product, replace or modify the Product so as to make it noninfringing, or offer to accept return of the Product and refund the purchase price less a reasonable allowance for depreciation. Notwithstanding the foregoing, Seller is not liable for claims of infringement based on information provided by Buyer, or directed to Products delivered hereunder for which the designs are specified in whole or part by Buyer, or infringements resulting from the modification, combination or use in a system of any Product sold hereunder. The foregoing provisions of this Section constitute Seller’s sole and exclusive liability and Buyer’s sole and exclusive remedy for infringement of Intellectual Property Rights.
  - 19. Entire Agreement.** This agreement contains the entire agreement between the Buyer and Seller and constitutes the final, complete and exclusive expression of the terms of sale. All prior or contemporaneous written or oral agreements or negotiations with respect to the subject matter are herein merged. The terms contained herein may not be modified unless in writing and signed by an authorized representative of Seller.
  - 20. Compliance with Laws.** Buyer agrees to comply with all applicable laws, regulations, and industry and professional standards of care, including those of the United Kingdom, the United States of America, and the country or countries in which Buyer may operate, including without limitation the U. K. Bribery Act, the U.S. Foreign Corrupt Practices Act (“FCPA”), the U.S. Anti-Kickback Act (“Anti-Kickback Act”) and the U.S. Food Drug and Cosmetic Act (“FDCA”), each as currently amended, and the rules and regulations promulgated by the U.S. Food and Drug Administration (“FDA”), and agrees to indemnify and hold harmless Seller from the consequences of any violation of such provisions by Buyer, its employees or agents. Buyer acknowledges that it is familiar with the provisions of the U. K. Bribery Act, the FCPA, the FDA, and the Anti-Kickback Act, and certifies that Buyer will adhere to the requirements thereof. In particular, Buyer represents and agrees that Buyer will not make any payment or give anything of value, directly or indirectly to any governmental official, any foreign political party or official thereof, any candidate for foreign political office, or any commercial entity or person, for the purpose of influencing such person to purchase Products or otherwise benefit the business of Seller.

Part Number Index
Safety Guide
Offer of Sale
Part Number Index, Safety Guide, Offer of Sale

